



Proven Performance
for Over 50 Years

Precision Turbine Flow Meters - Flanged Series

ADVANTAGES

- High accuracy
- Wide flow range
- Fast response to rate changes
- Simplicity of construction with few parts
- Cost effective
- Calibration traceable to NIST

Flange Series— Identical to the AN Series, except for a few minor variations in size, end connections, and construction (to permit use in industrial applications). This series incorporates flanged end connections with ball bearings. The Flange Series finds wide usage in the automotive, petroleum products, and aerospace fields.

HIGH-REPEATABILITY FLOW METERS

INSTALLATION

COX Turbine Flowmeters mount directly in the line and can be installed in any position without affecting performance.

To reduce flow turbulence, a straight section of tube approximately 10 diameters in length upstream of the flowmeter is recommended, and a similar section about 5 diameters downstream.

Where impractical due to space limitations, careful attention to location of valves, bends, etc., is suggested. (Flow straightener sections are available from COX). Upstream filtration (10 micron) is also helpful to extend bearing life and to prevent possible damage to the rotor, but is not an absolute necessity.

Electrical installation requires 2-conductor shielded cable to the readout device.

Performance Specifications

Turbine Meter Accuracy (% of reading)	±0.25%
Repeatability (% of reading)	±0.02%*
Frequency Output (maximum)	1200 to 1500 Hz Standard 2400 Hz Optional
Pressure Rating	150 - 600# ANSI Class Rating
Output Signal (minimum)	10 millivolts
Response Time (milliseconds)	2-3 or better

*Statistically derived at 90% confidence level



Precision Turbine Flow Meters - Flanged Series

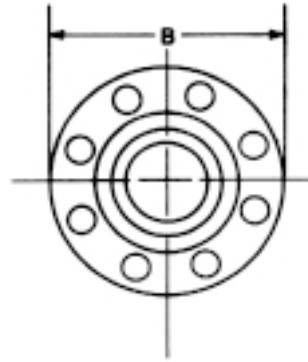
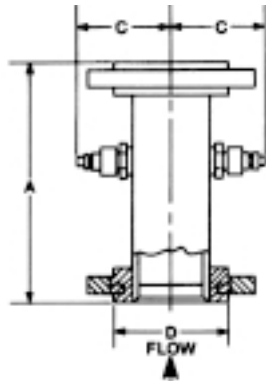

TABLE 5 - U.S.

COX Model	A	B 150 LB. FLG.*	B 300 LB. FLG.*	B 600 LB. FLG.*	C	D
F-½ (8-4)	5.00	3.50	3.75	3.75	4.18	1.38
F-½ (8-6)	5.00	3.50	3.75	3.75	4.21	1.38
F-½ (8)	5.00	3.50	3.75	3.75	4.27	1.38
F-¾ (10)	5.00	3.88	4.62	4.62	4.34	1.69
F-¾ (12)	5.00	3.88	4.62	4.62	4.41	1.69
F-1	8.00	4.25	4.88	4.88	4.53	2.00
F-1¼	8.00	4.62	5.25	5.25	4.63	2.50
F-1½	9.00	5.00	6.12	6.12	4.75	2.88
F-2	9.00	6.00	6.50	6.50	5.00	3.62
F-2½	10.00	7.00	7.50	7.50	5.25	4.12

*ANSI raised face integral flanges.

TABLE 5 - METRIC

COX Model	A MM	B MM 150 LB. FLG.*	B MM 300 LB. FLG.*	B MM 600 LB. FLG.*	C MM	D MM
F-½ (8-4)	127	89	95	92	106	35
F-½ (8-6)	127	89	95	92	107	35
F-½ (8)	127	89	95	92	108	35
F-¾ (10)	127	99	117	117	110	43
F-¾ (12)	127	99	117	117	112	43
F-1	203	108	124	124	115	51
F-1¼	203	117	133	133	118	64
F-1½	229	127	155	155	120	73
F-2	229	152	165	165	127	92
F-2½	254	178	191	191	133	105

*ANSI raised face integral flanges.

TABLE 6

MAGNETIC PICKUP			MODULATED CARRIER PICKUP		
COX Model	Model for Reference Only	Specifications	COX Model	Model for Reference Only	Specifications
F-½"(8-4)-(*)	AN 8-4	For Specifications, see Bulletin 42-AN	FC-½"(8-4)-(*)	ANC 8-4	For Specifications, see Bulletin 42-AN
F-½"(8-6)-(*)	AN 8-6		FC-½"(8-6)-(*)	ANC 8-6	
F-½"(8)-(*)	AN 8		FC-½"(8)-(*)	ANC 8	
F-¾"(10)-(*)	AN 10		FC-¾"(10)-(*)	ANC 10	
F-¾"(12)-(*)	AN 12		FC-¾"(12)-(*)	ANC 12	
F-1"(*)	AN 16		FC-1"(*)	ANC 16	
F-1¼"(*)	AN 20		FC-1¼"(*)	ANC 20	
F-1½"(*)	AN 24		FC-1½"(*)	ANC 24	
F-2"(*)	AN 32		FC-2"(*)	ANC 32	
F-2½"(*)	AN 40				

*Specify Flange rating 150, 300 or 600 lb.

For more information, contact COX Instruments
or your local COX Instruments representative.



Proven Performance
for Over 50 Years

15555 North 79th Place • Scottsdale, AZ 85260
tel: (480) 922-7446 • tel: (480) 948-3610
www.cox-instruments.com