



Proven Performance  
for Over 50 Years

# Precision Turbine Flow Meters—AN Series

## FOR HIGH-ACCURACY LABORATORY AND TESTING MEASUREMENTS

### ADVANTAGES

- High accuracy
- Wide flow range
- Fast response to rate changes
- Simplicity of construction with few parts
- Cost effective
- Calibration traceable to NIST

### DESCRIPTION

A flowmeter design with exceptionally wide application in the areas of testing and control. AN (MS) fittings and a wide range of sizes meet the requirements of most applications. Guaranteed accuracy is  $\pm 0.25\%$  of reading.

With standard K factor (10:1 flow ratio) calibration, frequency output is linear to within  $\pm 0.5\%$  over the entire flow range with liquids up to 1.5 centistokes viscosity. With special calibration  $\pm 0.5\%$  linearity can be achieved at any one viscosity up to the linear viscosity limit shown in Table 3. At higher viscosities, output is non-linear, but repeatable.

Standard K ranges are available from 0.25-2.5 to 25-250 gpm, depending upon meter size. K-Factor calibrations are available on MIL-C-7024C, Type 2 at 80°F only.

With 20-point loop calibrations (10 points upscale and 10 points down-scale)  $\pm 0.5\%$  linearity, over the extended ranges shown in Table 3, is available on fluids where viscosity does not exceed 1.5 centistokes. Standard extended ranges are available from 0.25-3.0 to 6.2-300 gpm depending on meter size.

Performance Specifications	
Turbine Meter Accuracy (% of reading)	$\pm 0.25\%$
Repeatability (% of reading)	$\pm 0.02\%$
Frequency Output (maximum)	1200 to 1500 Hz Standard 2400 Hz Optional
Pressure Rating (at 75°F)	See Charts
Output Signal (minimum)	10 millivolts
Response Time (milliseconds)	2-3 or better



# Precision Turbine Flow Meters—AN Series

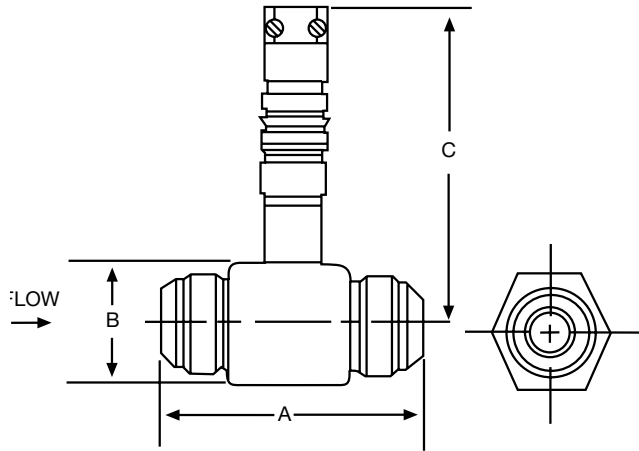

TABLE 2- Dimensions also apply to ANC Series meters.

Cox Model	A IN	B IN	C IN	Tube Size (inches)
AN 8-4	2.45	1.12†	4.19	1/2
AN 8-6	2.45	1.12†	4.22	1/2
AN 8	3.45	1.12†	4.25	1/2
AN 10	2.72	1.25†	4.43	5/8
AN 12	3.25	1.25†	4.41	3/4
AN 16	3.56	1.63*	4.53	1
AN 20	4.06	1.88*	4.63	1 1/4
AN 24	4.59	2.25*	4.75	1 1/2
AN 32	6.06	2.75*	5.00	2
AN 40	8.50	3.50*	5.25	2 1/2

\*Hex Body †Square Body

## ENGLISH UNITS

TABLE 3- With 20 Point Loop and standard K FACTOR Calibrations. Frequency output is linear over the entire flow range with the liquids up to 1.5 centistokes. With 20 point calibration, output is linear at any one specific (calibrated) viscosity within the LINEAR VISCOSITY LIMIT shown. (Frequency output 120-1200 Hz)

COX Model	K Range			Cycles/ Gallon (K Factor)	Extended Range†			
	Gallons/ minute	Pounds/ Hour	**Δp		Gallons/ minute	Pounds/ Hour	Freq. Output (Hz)	Flow Ratio
AN 8-4	0.25-2.5	95-950	3.5	28,800	0.25-3.0	95-1140	120/144	1:12
AN 8-6	0.50-5.0	190-1900	4.5	14,400	0.50-6.0	190-2280	190/228	1:12
AN 8	0.75-7.5	285-2850	6.0	9,600	0.60-9.0	230-3420	230/342	1:15
AN 10	1.25-12.5	475-4750	5.0	5760	1.0-15	380-5700	96/1440	1:15
AN 12	2.5-25	950-9500	5.0	2800	1.5-30	570-11,400	72/1440	1:20
AN 16	5.0-50	1900-19,000	5.0	1440	2.5-60	950-22,800	60/1440	1:24
AN 20	7.5-75	2850-28,500	5.5	960	3.0-90	1140-34,200	48/1440	1:30
AN 24	12.5-125	4750-47,500	6.0	576	5.0-150	1900-57,000	48/1440	1:30
AN 32	25-250	9500-95,000	6.5	288	6.2-300	2375-114,000	30/1440	1:48
AN 40	50-500	19,000-190,000	6.0	144	12.5-600	4750-228,000	30/1440	1:48

\*\* Pressure drop in Table 3 based upon liquid, specific gravity 0.76 at 1200 Hz and PPH Ranges are based on MIL-C-7024C, Type 2 at 80°F.

† EXTENDED RANGE-With 20-point Calibration, frequency output is linear over entire range with liquids up to 1.5 centistokes. Over 2.0 centistokes output is non-linear but repeatable.

TABLE 4- For meter dimensions, see Table 2.

COX Model	Linear Range†		Linear Flow Ratio	Repeatable Range		Repeatable Flow Ratio	Δp†	Freq. @ Max. Flow
	Gallons/ minute	Pounds/ Hour**		Gallon/ minute	Pounds/ Hour			
ANC 8-4	0.20-3.0	76-1,140	15-1	0.05-3.0	19-1,140	60-1	6.5	1500 Hz
ANC 8-6	0.30-6.0	114-2,280	20-1	0.06-6.0	23.5-2,280	100-1	8.5	
ANC 8	0.40-9.5	152-3,600	24-1	0.09-9.5	35.5-3,600		8.5	
ANC 10	0.50-15.5	190-5,900	30-1	0.16-15.5	59-5,900	9.0		
ANC 12	1.00-30	380-11,400	30-1	0.30-30	114-11,400	9.0		
ANC 16	1.60-65	610-24,700	40-1	0.45-65	170-24,700	150-1	9.0	
ANC 20	1.90-95	720-36,000	50-1	0.65-95	247-36,000		8.5	
ANC 24	2.60-155	990-59,000	60-1	1.05-155	400-59,000	9.0		
ANC 32	3.10-310	1,180-11,800	100-1	2.10-310	800-118,000	9.0		

\*\* Based on Maximum Flow Condition (1500 Hz)

† Linearity and Repeatability is based on using a hydrocarbon fuel at one centistoke; not applicable to water.

Note 1. The Modulated Carrier Series requires signal conditioning. When ordering AN/ANC meters, please specify linear or non-linear (repeatable) calibration.

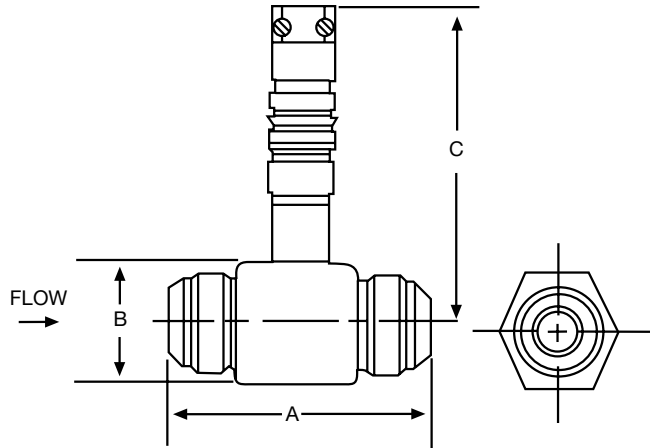

TABLE 2- Dimensions also apply to ANC Series meters.

Cox Model	A MM	B MM	C MM	Tube Size (inches)
AN 8-4	62	28†	106	1/2
AN 8-6	62	28†	107	1/2
AN 8	62	28†	108	1/2
AN 10	69	32†	110	5/8
AN 12	83	37†	112	3/4
AN 16	91	41*	115	1
AN 20	103	48*	118	1 1/4
AN 24	117	57*	121	1 1/2
AN 32	154	70*	127	2
AN 40	216	90*	133	1/2

\*Hex Body †Square Body

### METRIC UNITS

TABLE 3- With 20 Point Loop and standard K FACTOR Calibrations. Frequency output is linear over the entire flow range with the liquids up to 1.5 centistokes. With 20 point calibration, output is linear at any one specific (calibrated) viscosity within the LINEAR VISCOSITY LIMIT shown. (Frequency output 120-1200 Hz)

COX Model	K Range			Cycles/ liters (K Factor)	Extended Range†			
	Liters/ minute	Kilograms/ Hour	**Δp Kg/cm <sup>2</sup>		Liters/ minute	Kilograms/ Hour	Freq. Output (Hz)	Flow Ratio
AN 8-4	.946/9.46	43.0/431	.25	7610	.946/11.4	43.1/517	120/1440	1:12
AN 8-6	1.89/18.9	86.2/862	.32	3805	1.89/22.7	86.2/1034	190/2280	1:12
AN 8	2.84/28.4	129.3/1293	.42	2236	2.27/34.1	104/1551	230/3420	1:15
AN 10	4.731/47.3	216/2155	.35	.2642	3.79/56.8	172.4/2586	96/1440	1:15
AN 12	9.462/94.6	431/4309	.35	761	56.8/114	259/5171	72/1440	1:20
AN 16	18.92/189	862/8618	.35	380	9.46/227	431/10342	60/1440	1:24
AN 20	28.4/28.4	1293/12927	.39	254	11.4/341	517/15513	48/1440	1:30
AN 24	47.3/473	2155/21546	.42	152	18.9/568	862/25855	48/1440	1:30
AN 32	94.6/946	4309/43091	.03	76.089	23.5/1136	1077/5170	30/1440	1:48
AN 40	189/1893	8618/86183	.42	38.044	47.3/2271	2155/103419	30/1440	1:48

\*\* Pressure drop in Table 3 based upon liquid, specific gravity 0.76 at 1200 Hz and PPH Ranges are based on MIL-C-7024C, Type 2 at 80°.

† EXTENDED RANGE - With 20-point Calibration, frequency output is linear over entire range with liquids up to 1.5 centistokes.

Over 2.0 centistokes output is non-linear but repeatable.

TABLE 4- For meter dimensions, see Table 2.

COX Model	Linear Range†		Linear Flow Ratio	Repeatable Range		Repeatable Flow Ratio	Δp† Kg/c m <sup>2</sup>	Freq. @ Max. Flow
	Liters/ minute	Kilograms/ Hour**		Liters/ minute	Kilograms/ Hour			
ANC 8-4	.757-11.4	34.5/517	15-1	.189/11.4	8.6/517	60-1	.46	1500 Hz
ANC 8-6	1.14/22.7	51.7/1034.2	20-1	.227/22.7	10.7/1034		.60	
ANC 8	1.51/36	68.9/1633	24-1	.341/36	16.1/1633	100-1	.60	
ANC 10	1.89/59	86.2/2676	30-1	.605/59	26.7/2676		.63	
ANC 12	3.79/114	172.4/5171	30-1	1.14/114	51.7/5171		.63	
ANC 16	6.06/246	277/11204	40-1	1.70/246	77.1/11204		.63	
ANC 20	7.19/360	327/16329	50-1	2.46/360	112/16330	150-1	.60	
ANC 24	9.84/587	449/26762	60-1	3.97/587	181/26762		.60	
ANC 32	11.7/1173	535/53524	100-1	7.95/1173	363/53524		.63	

\*\* Based on Maximum Flow Condition (1500 Hz)

† Linearity and Repeatability is based on using a hydrocarbon fuel at one centistoke; not applicable to water.

Note 1. The Modulated Carrier Series requires signal conditioning. When ordering AN/ANC meters, please specify linear or non-linear (repeatable) calibration.

# Precision Turbine Flow Meters—AN Series

## PRESSURE-TEMPERATURE RATINGS OF COX AN SERIES TURBINE METER

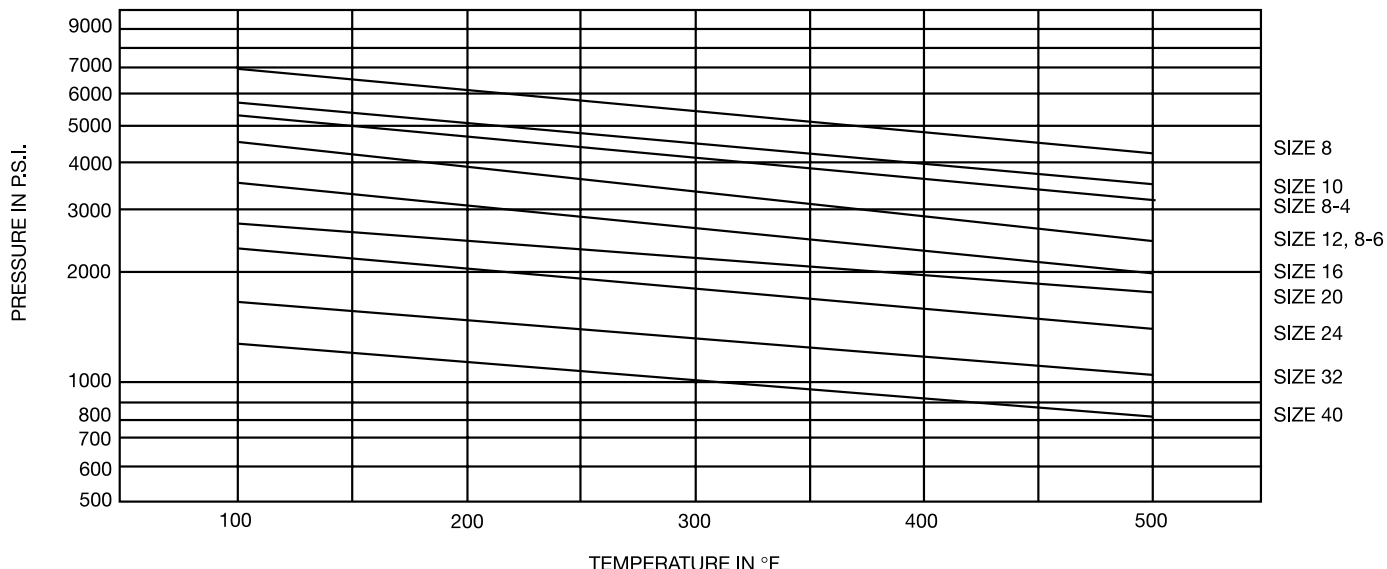

NOTE: The pressure ratings shown reflect a 6:1 factor of safety. For operation at pressures approaching the upper limits shown, care should be exercised in the selection of adequately pressure rated mating female connectors.

## INSTALLATION

COX Turbine Flowmeters mount directly in the line and can be installed in any position without affecting performance.

To reduce flow turbulence, a straight section of tube approximately 10 diameters in length upstream of the flowmeter is recommended, and a similar section about 5 diameters downstream.

Where impractical due to space limitations, careful attention to location of valves, bends, etc., is suggested. (Flow straightener sections are available from COX Instrument). Upstream filtration (10 micron) is also helpful to extend bearing life and to prevent possible damage to the rotor, but is not an absolute necessity.

Electrical installation requires 2-conductor, shielded cable to the readout device.

For more information, contact COX Instruments or your local COX Instruments representative.



*Proven Performance  
for Over 50 Years*

15555 North 79th Place • Scottsdale, AZ 85260  
tel: (480) 922-7446 • fax: (480) 948-3610  
[www.cox-instruments.com](http://www.cox-instruments.com)