





## TABLE OF CONTENTS

	DESCRIPTION	PAGE
<b>I.</b>	<b>GENERAL TECHNICAL INFORMATION</b> .....	1
	1. Design Features.....	1
	2. Operating Characteristics.....	2
	3. Step Response Time.....	2
	4. Overspeed.....	2
	5. Electrical Connections and Signal Transmission.....	2
	(i) Pickup Coils.....	2
	(ii) Transmission Cable.....	3
	(iii) Signal Output.....	3
	6. Process Piping and Connections.....	3
	7. Construction Details.....	4
	(i) Turbine Shaft Support.....	4
	(ii) Rotor Blades.....	4
	(iii) Retainer Rings.....	4
	(iv) Housing Material.....	4
	8. Calculation Aids.....	5
	(i) Symbology and Meaning.....	5
	(ii) Conversion of Units.....	5
	9. K-Factor Determination.....	5
	10. Pressure Drop.....	5
	11. Viscosity.....	8
	12. Gas Purging.....	12
<b>II.</b>	<b>INSTALLATION</b> .....	13
	(i) Piping.....	13
<b>III.</b>	<b>OPERATIONS</b> .....	14
	(i) Starting-up Precautions.....	14
	(ii) Conduit-Type Wiring.....	14
	(iii) Wiring Using a Connection Box.....	14
	(iv) Wiring Using a Field-Mounted Preamplifier.....	14
	1. Symptoms, Probable Causes, and Solutions.....	16
<b>IV.</b>	<b>MAINTENANCE</b> .....	17
	1. Maintenance Tools.....	17
	(i) For 1/2 and 5/8 Inch Flowmeters.....	17
	(ii) For 3/4 and 2 Inch Flowmeters.....	17
	2. Reference Instructions.....	17
	3. Calibration.....	17
	4. Coil Removal and Installation.....	18
	(i) Coil Removal.....	18
	(ii) Coil Installation.....	18
	5. Coil Test.....	18
	6. Disassembly and Assembly Procedures for 1/2" Sizes.....	19
	(i) Disassembly.....	19
	(ii) Assembly.....	19
	7. Disassembly and Assembly Procedures for Sizes 3/4" and Larger.....	20
	(i) Disassembly.....	20
	(ii) Assembly.....	20
<b>V.</b>	<b>PARTS LIST</b> .....	21
<b>VI.</b>	<b>DIMENSIONS</b> .....	23

## LIST OF ILLUSTRATIONS

FIGURE	DESCRIPTION	PAGE
1.	Cutaway Drawing of 81AT4 Flowmeter with Reduced Bore.....	1
2.	Cutaway Drawing of 81AF Flange End Flowmeter.....	2
3.	Cutaway Drawing of 81T3 Flared Tube End Flowmeter with Reduced Bore.....	2
4.	Minimum Operating Pulse Rates and Voltages for 81A and 81T Turbine Flowmeters.....	3
5.	K-Factor and Mean K-Factor.....	7
6.	General Effect of Increased Viscosity.....	8
7.	Viscosity Effect-Size Prefix Code 1/2-2 for 81A/81T.....	9
8.	Viscosity Effect-Size Prefix Code 1/2-1 for 81A/81T.....	9
9.	Viscosity Effect-Size Prefix Code 1/2 for 81A and 5/8-1 for 81T..	9
10.	Viscosity Effect-Size Prefix Code 3/4 and 1-1 for 81A, and 3/4 for 81T.....	9
11.	Viscosity Effect-Size Prefix Code 1 for 81A/81T.....	9
12.	Viscosity Effect-Size Prefix Code 1 1/2 for 81A/81T.....	10
13.	Viscosity Effect-Size Prefix Code 2 for 81A/81T.....	10
14.	Viscosity Effect-Size Prefix Code for 81A Only.....	10
15.	Viscosity Effect-Size Prefix Code 4 for 81A Only.....	10
16.	Viscosity Effect-Size Prefix Code 6 for 81A Only.....	10
17.	Viscosity Effect-Size Prefix Code 8 for 81A Only.....	11
18.	Viscosity Effect-Size Prefix Code 10 for 81A Only.....	11
19.	Viscosity Effect-Size Prefix Code 12 for 81A Only.....	11
20.	Maximum Recommended Purge Rate Versus Density.....	12
21.	Flowmeter Handling and Alignment.....	13
22.	Flowmeter Installation with Shutoff Valves.....	13
23.	Wiring Using a Connector Box.....	15
24.	Wiring Using a Field-Mounted Preamplifier.....	15
25.	Coil Removal and Installation.....	18
26.	Coil Test.....	18
27.	Disassembly Procedures for 1/2" Sizes.....	19
28.	Disassembly and Assembly Procedures for Sizes 3/4" and Larger.....	20

## LIST OF TABLES

TABLE	DESCRIPTION	PAGE
1.	Symbology and Meaning.....	4
2.	Conversion of Units.....	5
3.	81A Series Turbine Flowmeter Capacities Based on Water at 15.6°C (60°F).....	7
4.	81A Turbine Flowmeter Capacities for Model Code Suffix-A*, Water at 15.6°C (60°F) * -A=High Pulse Output.....	7
5.	81T Turbine Flowmeter Capacities Based on Water at 15.6°C (60°F).....	7

In industrial flow measurement, dependable performance and flowmeter longevity are very important. With 81A and 81T Turbine Flowmeters, these features combine with high measurement precision over a wide range of flow rates.

## I. GENERAL TECHNICAL INFORMATION

Every 81A and 81T Series Flowmeter produces a high-resolution pulse rate output signal. The signal is proportional to the velocity of liquid flowing through the flowmeter and hence, to volumetric flow rate. A magnetic pickup coil is mounted on the outside of the flowmeter housing. As the turbine wheel in the flowmeter rotates and as each metal turbine blade passes the pickup coil, the flux density of the coil is changed, thus inducing a single voltage pulse. Each pulse represents the finite volume of liquid that was in the space between consecutive rotor blades. The pulse rate is a very accurate measure of flow rate, and the total number of pulses is an equally accurate

measure of the total volume that has passed through the flowmeter. With digital readout devices, this accuracy is maintained within  $\pm 1$  count.

### 1. DESIGN FEATURES

The 81A Flowmeters are offered with either pipe thread or ANSI Class 150/300/600 flange end connections. The 81T Flowmeter has flared tube end connections. They both have exceptional simplicity of construction. As shown in the exploded view drawings (Figures 1,2,3), there is a minimum number of parts. The flowmeters are easily disassembled for inspection and cleaning. And, reassembly or bearing replacement does not cause a shift in the calibration factor for 25 mm (1 in) and larger units. Straightening vanes are permanently mounted in the housings and do not require removal, except in reduced bore versions having size prefix codes 1/2-2, 1/2-1, and 5/8-1.

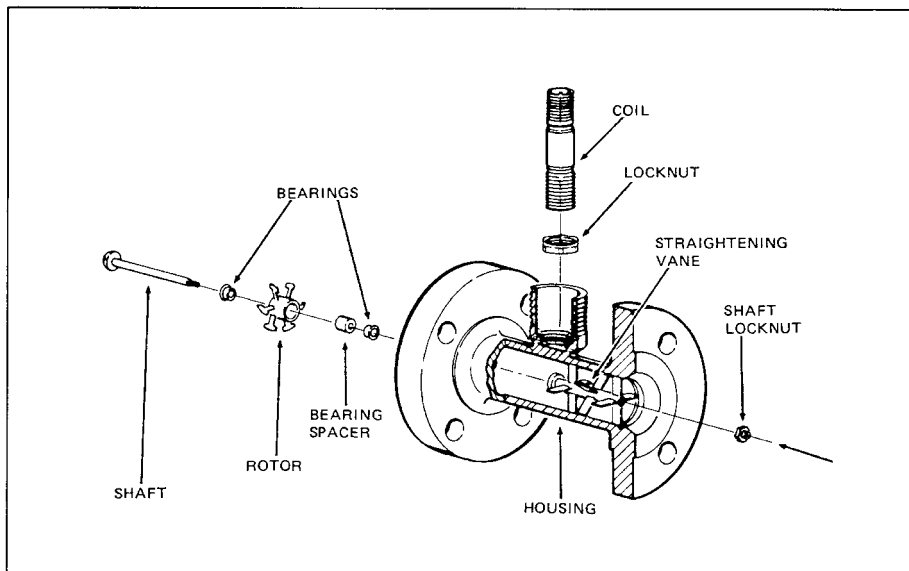

**Figure 1. Cutaway Drawing of 81AT4 Flowmeter with Reduced Bore**

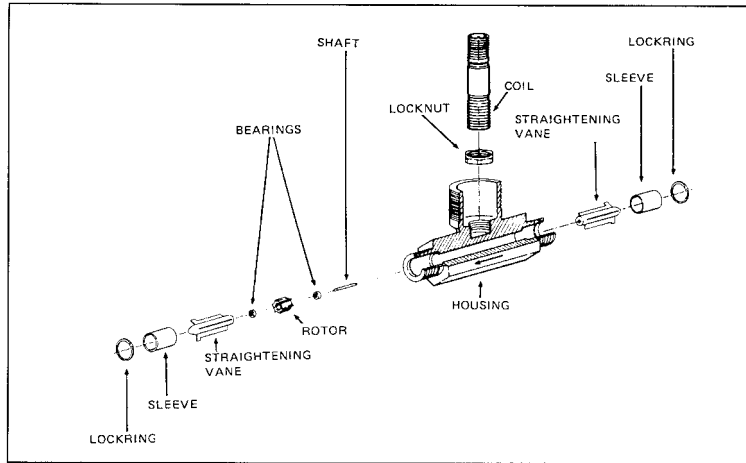

**Figure 2. Cutaway Drawing of 81AF Flange End Flowmeter**

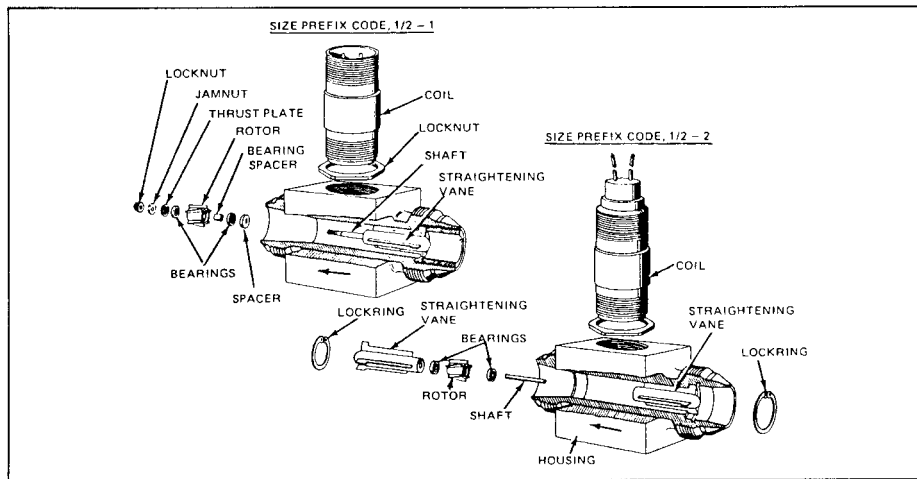

**Figure 3. Cutaway Drawing of 81T3 Flared Tube End Flowmeter with Reduced Bore**

**2. OPERATING CHARACTERISTICS**

Linear flow rate ranges and operating flow rate ranges are very wide, with turn-down ratios up to 30:1 and higher in larger sizes. This versatility is coupled with high accuracy and repeatability.

**3. STEP RESPONSE TIME**

The 81A and 81T Turbine Flowmeters have practically instantaneous response to flow rate changes. Response varies according to the size of the flowmeter. After a step change in flow rate, only 6 to 25 milliseconds are required. Each coil is furnished as standard with a 2-pin plug type 1OSL-4P shell, 0.625-24 UNEF thread with mating connector MS 3106A-

necessary for the output signal to reach 63% of the new flow rate value.

**4. OVERSPEED**

These Flowmeters are designed to withstand overspeeds to one and one half (1.5) times the maximum rated flow rate for short durations.

**5. ELECTRICAL CONNECTIONS AND SIGNAL TRANSMISSION**

**(i) Pickup Coils**

1OSL-45(C). The connector contains two permanently attached 0.9 m (3 ft) leads.

(ii) **Transmission Cable**

Two conductor 18 AWG screened (shielded) cable is recommended for use with all Flowmeters.

(iii) **Signal Output**

These Flowmeters generate an approximate sine wave ac voltage output. Minimum operating pulse rates and voltages for 81A and 81T Flowmeters are shown in Figure 4. Digital and analog devices are designed to accept these voltages and pulse rate levels.

**6. PROCESS PIPING AND CONNECTIONS**

Flowmeters should be installed with adjacent straight pipe upstream (a length of 10 pipe diameters) and downstream (5 diameters). The pipe should be the same nominal size as the flowmeter connection. The 81A and 81T Flowmeters are designed for installation in a horizontal line, and flow must be in the direction indicated by an arrow on the housing.

A strainer should be installed upstream of the flowmeter to assure protection against particle contamination. Strainers also provide protection against damage by large solid objects that accidentally enter the process line. Recommended mesh sizes, given in the table below, are a function of flowmeter size.

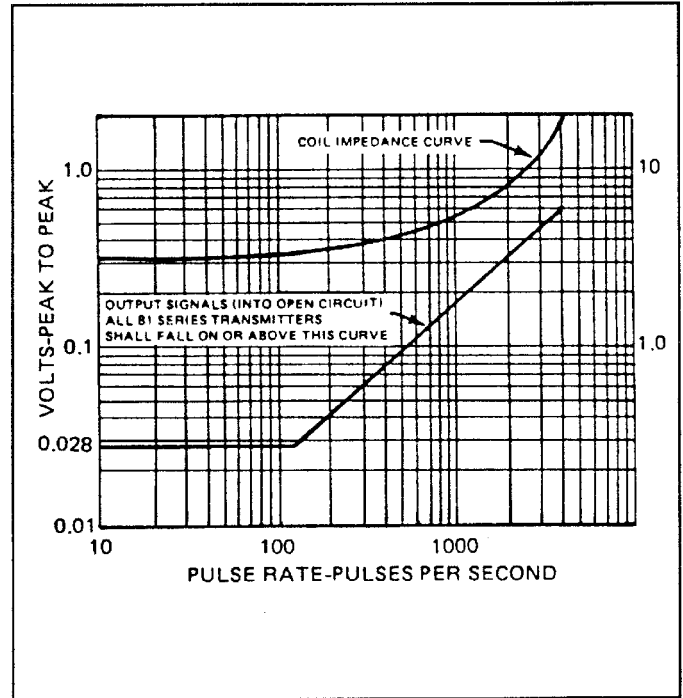

**Figure 4. Minimum Operating Pulse Rates and Voltages for 81A and 81T Turbine Flowmeters**

Flowmeter Line Size		Mesh Number	Hole Size	
mm	in		mm	In
15 and 20	1/2 and 3/4	100	0.150	0.0059
25 to 80	1 to 3	80	0.178	0.0070
100 and 150	4 and 6	60	0.249	0.0098
200 to 300	8 to 12	40	0.419	0.0165

**7. CONSTRUCTION DETAILS**

**(i) Turbine Shaft Support**

The exploded view drawings illustrate the simplicity of design. In all sizes 3" and above, the turbine shaft is supported on one end only. This "cantilevered construction" eliminates possible bearing and rotor alignment problems. Shaft support on one end simplifies removal of the rotor assembly and shaft. They can be taken out of the flowmeter housing by unscrewing a jamnut and/or a locknut. Bearing cleaning or parts replacement is literally reduced to minutes. Reduced bore construction is shown in Figures 1 and 3. In the size prefix Code 1/2-2 to 2" flowmeter, the rotor shaft is supported at both ends to allow greater strength and proper blade tip clearance in this smallest unit. Bearing parts distortion is eliminated and there is reduced pressure drop with this design. Double-ended rotor shaft support also permits bi-directional measurement.

**(ii) Rotor Blades**

Typical turbine flowmeter calibration curves tend to rise as the low end of the linear range is approached. This effect is controlled by

optimizing the tip clearance between the rotor and the housing wall. The unique "T-Blade" rotor shape provides a flat calibration curve in 3/4 to 2" sizes. At the same time, it generally permits greater tip clearance than with conventional blades. The T-Blade is illustrated in Figure 2.

**(iii) Retainer Rings**

Three different ball bearing retainer ring materials are available in 81A and 81T Turbine Flowmeters. Stainless steel retainer rings are used in 20 mm (3/4 in) and the smaller flowmeters. On 25 through 300 mm (1 through 12 in) flowmeters, there is an option of either stainless steel, nylon or phenolic retainer rings. In all sizes, the ball material is stainless steel. Unless there is a corrosion or high temperature problem, phenolic retainer rings should be specified for longest life. See Cox Bulletin 81-TM for information on a variety of industrial process liquids and the turbine flowmeter materials that can be used with them.

**(iv) Housing Material**

The housing material for all flowmeters is stainless steel.

U.S. Customary		SI		Description
Symbol	Units	Symbol	Units	
FHz	Hz or pps	FHz	Hz or pps	Frequency (pulse rate) in Hz or pps
Gcal	-	Gcal	-	Reference Density (Specific Gravity) of calibration liquid (usually water)
Gliq	-	Gliq	-	Reference Density (Specific Gravity) of process liquid
KF	p/U.S. gal	K*F	p/L	K-Factor in pulses per U.S. gallon, or pulses per litre
$\Delta P_{act}$	psi	$\Delta P^*_{act}$	kPa	Pressure drop at actual (selected) flow rate in psi or kPa
$\Delta P_{max}$	psi	$\Delta P^*_{max}$	kPa	Pressure drop at maximum flow rate in psi or kPa
$\Delta P_{cal}$	psi	$\Delta P^*_{cal}$	kPa	Pressure drop with calibration liquid (usually water) in psi or kPa
$\Delta P_{liq}$	psi	$\Delta P^*_{liq}$	kPa	Pressure drop with process liquids in psi or kPa
Qgpm	U.S. gpm	Q lps	L/s	Volumetric flow rate in U.S. gpm or L/s
(qgmp) <sub>act</sub>	U.S. gpm	(q lps) <sub>act</sub>	L/s	Actual (selected) volumetric flow rate in U.S. gpm or L/s
(qgpm) <sub>max</sub>	U.S. gpm	(q lps) <sub>max</sub>	L/s	Maximum volumetric flow rate in U.S. gpm or L/s
(qgpm) <sub>cal</sub>	U.S. gpm	(q lps) <sub>cal</sub>	L/s	Volumetric flow rate at $\Delta P_{liq}$ or $\Delta P^*_{cal}$ in U.S. gpm or L/s
(qgpm) <sub>liq</sub>	U.S. gpm	(q lps) <sub>liq</sub>	L/s	Volumetric flow rate at $\Delta P_{liq}$ or $\Delta P^*_{liq}$ in U.S. gpm or L/s
( $\nu$ cP) <sub>cal</sub>	cP	( $\nu$ cP) <sub>cal</sub>	cP	Absolute viscosity of calibration liquid (usually water), in centipoises
( $\nu$ cP) <sub>liq</sub>	cP	( $\nu$ cP) <sub>liq</sub>	cP	Absolute viscosity of process liquid, in centipoises

**Table 1. Symbology and Meaning**

**8. CALCULATION AIDS**

“Flow Measurement Engineering Handbook.”

**(i) Symbology and Meaning**

Table 1 lists the symbols (and their meaning) used in the equations in this TI. Both I.S. Customary and SI symbols are listed. The asterisk indicates SI symbols. The symbology is consistent with that found in R.W. Miller’s

**(ii) Conversion of Units**

Table 2 lists factors for converting to the U.S. Customary or SI units used in the equations that follow. This table is presented as a convenient tool, and can be used as required.

**Table 2. Conversion of Units**

To Convert	Multiply By	To Obtain	To Convert	Multiply By	To Obtain
inH <sub>2</sub> O	0.03606	psi	bar	100	kPa
ftH <sub>2</sub> O	0.4328	psi	kg/cm <sup>2</sup>	98.07	kPa
inHg	0.4912	psi	inH <sub>2</sub> O	0.2487	kPa
ft <sup>3</sup> /min	7.480	U.S. gpm	mmHg	0.1333	kPa
Ft <sup>3</sup> /h	0.1247	U.S. gpm	L/min	0.01667	L/s
U.S. gph	0.01667	U.S. gpm	m <sup>3</sup> /h	0.2778	L/s
IMP gpm	1.200	U.S. gpm	L/s	60	L/min
IMP gpm	0.0200	U.S. gpm	m <sup>3</sup> /h	16.67	L/min

centipoises X (1/specific gravity) = centistokes  
 centistokes X specific gravity = centipoises  
 bar gauge + 1.0 bar = bar absolute  
 kPa gauge + 101.3 kPa = kPa absolute  
 psi gauge + 14.7 psi = psi absolute

**9. K-FACTOR DETERMINATION**

Cox Instrument calibrates each turbine flowmeter with water prior to shipment. Calibration in other liquids can be done upon request. A calibration report is included with each turbine flowmeter. A mean calibration factor is determined from data documented on a calibration data sheet relative to a specific flow range.

The K-factor represents pulses per U.S. Gallon and is defined in the following equations.

In U.S. Customary Units:

$$(1) \quad K_f = \frac{(60)(fHz)}{qgpm}$$

and in SI Units:

$$K^*_F = \frac{(fHz)}{q^*lps}$$

This figure is used to standardize or preset any readout equipment. The K-factor and the mean K-factor (average K value over the linear flow range) are graphically illustrated in Figure 5.

**10. PRESSURE DROP**

Tables 3, 4, and 5 give pressure drop values at maximum rated flow rates. This information is based on water, relative density (specific gravity) = 1.0 centipoise, at 15.60°C (60°F). Pressure drop values at flow rates below maximum can be calculated. The pressure drop corresponding to maximum flow is multiplied by the square of the selected flow rate divided by the maximum flow rate. Or referring to Equations 2 and 3:

In U.S. Customary Units:

$$(2) \Delta P_{act} = \Delta P_{max} \left[ \frac{(q_{gpm})_{act}}{(q_{gpm})_{max}} \right]^2$$

and in SI Units:

$$(3) \Delta P^*_{act} = \Delta P^*_{max} \left[ \frac{(q^*_{lps})_{act}}{(q^*_{lps})_{max}} \right]^2$$

When the process liquid has a relative density (specific gravity) and/or viscosity value different than the liquid with which the flowmeter was calibrated (usually water), another more elaborate equation for calculating pressure drop in a turbine flowmeter is used. This equation includes relative density and viscosity considerations in addition to flow rate effects. Referring to Equations 4 and 5:

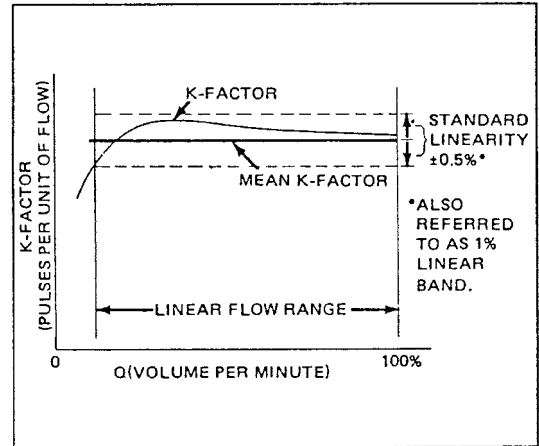

Figure 5. K-Factor and Mean K-Factor

In U.S. Customary Units:

$$(4) \Delta P_{liq} = \Delta P_{cal} \left( \frac{G_{liq}}{G_{cal}} \right)^{0.81} \left[ \frac{(\mu P)_{liq}}{(\mu P)_{cal}} \right]^{0.27} \left[ \frac{(q_{gpm})_{liq}}{(q_{gpm})_{cal}} \right]^{1.82}$$

and in SI Units:

$$(5) \Delta P^*_{liq} = \Delta P^*_{cal} \left( \frac{G_{liq}}{G_{cal}} \right)^{0.81} \left[ \frac{(\mu P)_{liq}}{(\mu P)_{cal}} \right]^{0.27} \left[ \frac{(q^*_{lps})_{liq}}{(q^*_{lps})_{cal}} \right]^{1.82}$$

A simplified equation which also takes into account variations in relative density and/or viscosity (although not as accurately) is more easily used. Referring to Equations 6 and 7.

In U.S. Customary Units:

$$(6) \Delta P_{liq} = \Delta P_{cal} \left( \frac{G_{liq}}{G_{cal}} \right) \left[ \frac{(\mu P)_{liq}}{(\mu P)_{cal}} \right]^{0.25} \left[ \frac{(q_{gpm})_{liq}}{(q_{gpm})_{cal}} \right]^2$$

and in SI Units:

$$(7) \Delta P^*_{liq} = \Delta P^*_{cal} \left( \frac{G_{liq}}{G_{cal}} \right) \left[ \frac{(\mu P)_{liq}}{(\mu P)_{cal}} \right]^{0.275} \left[ \frac{(q^*_{lps})_{liq}}{(q^*_{lps})_{cal}} \right]^2$$

Size Code	Recommended Flow Rate Limits for $\pm 0.5\%$ Linearity		Typical K-Factor		Typical Pulse Rate at Max Flow Rate	Maximum Pressure Drop Based on Water at Maximum Flow Rate	
	L/s	U.S. gpm	p/L	P/U.S. gal	pps	kPa	psi
1/2-2	0.015 and 0.13	0.23 and 2.0	7926	30000	1000	20	3
1/2-1	0.025 and 0.25	0.4 and 4.0	6341	2400	1600	40	6
1/2	0.04 and 0.51	0.6 and 8.0	1982	7500	100	55	8
3/4	0.08 and 1.6	1.25 and 25	951	3600	1500	45	6.5
1-1	0.08 and 1.6	1.25 and 25	951	3600	1500	45	6.5
1	0.22 and 3.2	3.5 and 50	185	700	583	40	6
1 1/2	0.47 and 7.6	7.5 and 120	66	250	500	40	6
2	0.44 and 14.0	7.0 and 220	63	240	880	50	7.5
3	1.3 and 40	20 and 640	12	45.3	483	40	6
4	3.5 and 73	55 and 1150	6.0	22.6	452	28	4
6	6.2 and 150	100 and 2400	2.3	8.51	341	30	4.5
8	10 and 250	160 and 4000	1.1	4.02	268	35	5
10	21 and 390	325 and 6200	0.66	2.48	257	35	5
12	25 and 560	400 and 8800	0.44	1.65	242	35	5

**Table 3. 81A Series Turbine Flowmeter Capacities based on Water at 15.6°C (60°F)**

Size Code	Recommended Flow Rate Limits for $\pm 0.25\%$ Linearity		Typical K-Factor		Maximum Pressure Drop Based on Water at Maximum Flow Rate	
	L/s	U.S. gpm	p/L	p/bbl (1 bbl = 42 U.S. gal)	kPa	psi
4	8 and 73	130 and 1150	12.6	2000	55	8
6	19 and 150	300 and 2400	12.6	2000	40	6
8	32 and 250	500 and 4000	0.63	1100	40	6

**Table 4. 81A Turbine Flowmeter Capacities for Model Code Suffix-A\*, Water at 15.6°C (60°F)**  
 \*-A = High Pulse Output

Size Code Prefix <sup>(a)</sup>	Recommended Flow Rate Limits for $\pm 0.5\%$ Linearity		Typical K-Factor		Typical Pulse Rate at Max Flow	Maximum Pressure Drop Based on Water at Max Flow Rate	
	L/s	U.S. gpm	Pulses/L	Pulses/U.S. gal)	pps	kPa	Psi
1/2-2	0.015 and 0.13	0.23 and 2.0	7926	30000	1000	15	3.0
1/2-1	0.025 and 0.25	0.4 and 4.0	6341	24000	1600	50	6.0
5/8-1	0.04 and 0.51	0.6 and 8.0	1982	7500	1000	55	8.0
3/4	0.08 and 1.6	1.25 and 25	957	3600	1500	45	6.5
1	0.22 and 3.2	3.5 and 50	185	700	583	40	6.0
1 1/2	0.47 and 7.6	7.5 and 120	66	250	500	40	6.0
2	0.44 and 14.0	7.0 and 220	63	240	880	50	7.5

**Table 5. 81T Turbine Flowmeter Capacities based on Water at 15.6°C (60°F)**

## 11. VISCOSITY

The flow ranges shown in Tables 3, 4, and 5 are based on calibration in a liquid with a viscosity value of 1 mm<sup>2</sup>/s (centistoke). Note, that from Table 2, for a specific gravity of 1, centistokes equal centipoises. With a given liquid viscosity, there is a particular flow rate at which the rotor begins to turn because driving forces on the rotor overcome the drag or retarding forces. Beyond this flow rate, rotor speed is linear with liquid velocity.

As the viscosity of the liquid increases, greater liquid friction increases the drag forces on the rotor blades. Consequently, the linear relationship between liquid velocity and rotor speed will be altered and restricted to a smaller span of flow. The effect of increased viscosity is illustrated in Figure 6.

The curves shown in Figures 7 through 19 graphically show the effect of liquid viscosity on 81A and 81T Turbine Flowmeters. These curves can be used to estimate the performance of a specific size of meter on a liquid of given viscosity. With larger turbine flowmeters, there is less sensitivity to viscosity changes.

The precise effect of viscosity on a given transmitter can be determined by actual viscosity calibration. The linearity and mean K-factor relative to any selected flow range (within flowmeter limits) can be obtained from this data.

This calibration is generally in one of two forms. First, for applications in liquids with constant viscosity a 10-point calibration is performed in a liquid of comparable viscosity. Second, for applications in liquids with varying viscosity, two to four 10-point calibrations are performed. The calibrations are done at selected viscosities equally spaced over the required viscosity span. A universal calibration curve can then be drawn to cover this viscosity span for the entire range of the flowmeter.

A more precise method is to generate a separate curve for each specific viscosity requirement. This minimizes any error in drawing a smooth, continuous curve through numerous calibration points.

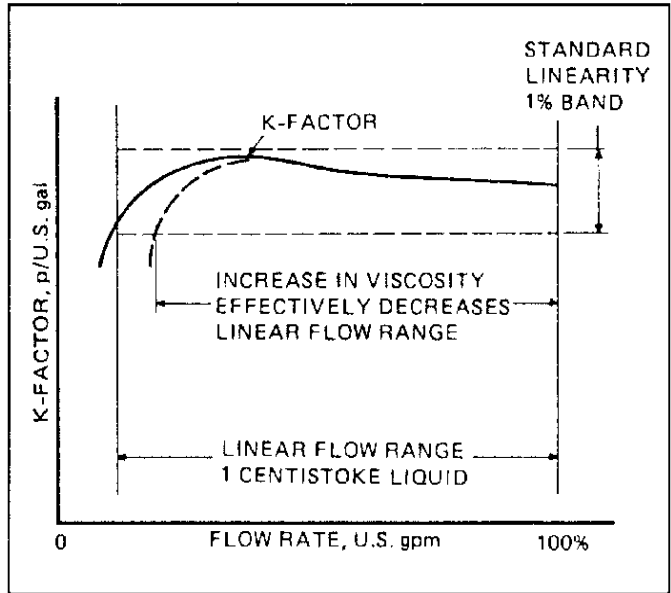

**Figure 6. General Effect of Increased Viscosity**

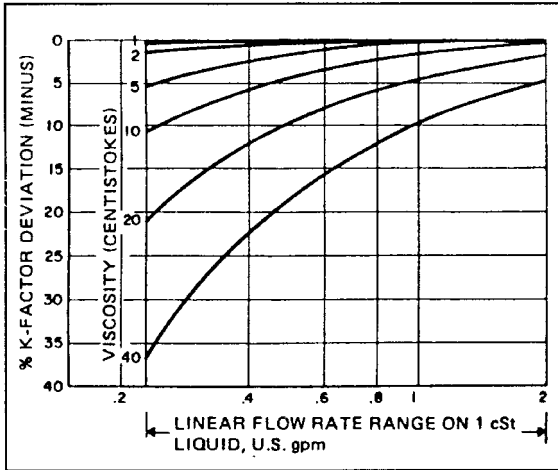

Figure 7. Viscosity Effect – Size Prefix Code  $\frac{1}{2}$ -2 for 81A/81T

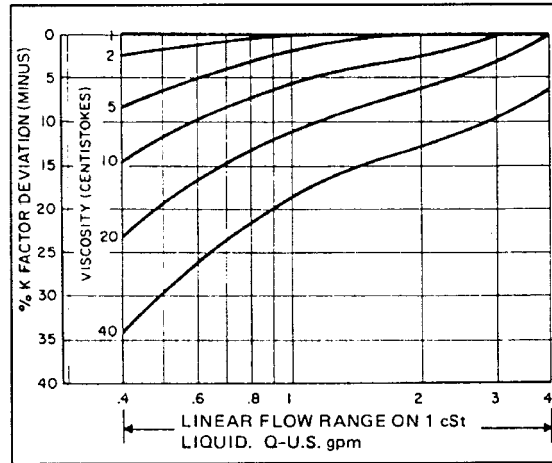

Figure 8. Viscosity Effect – Size Prefix Code  $\frac{1}{2}$ -1 for 81A/81T

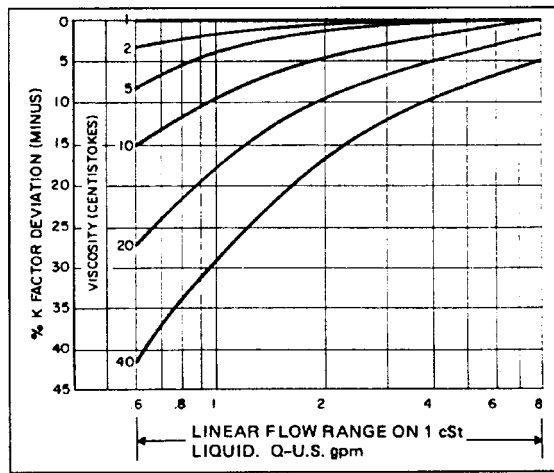

Figure 9. Viscosity Effect – Size Prefix Code  $\frac{1}{2}$  for 81A and 5/8-1 for 81T

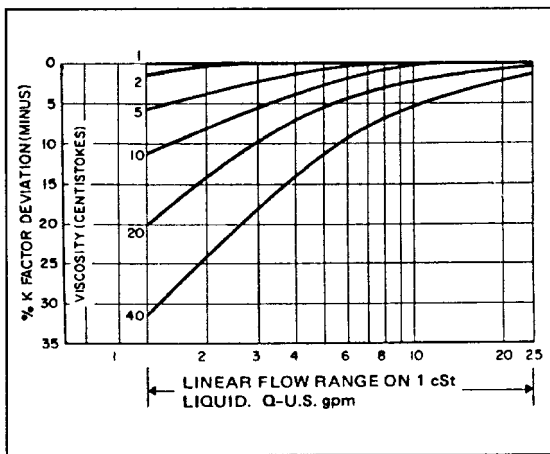

Figure 10. Viscosity Effect – Size Prefix Code  $\frac{3}{4}$  and 1-1 for 81A and  $\frac{3}{4}$  for 81T

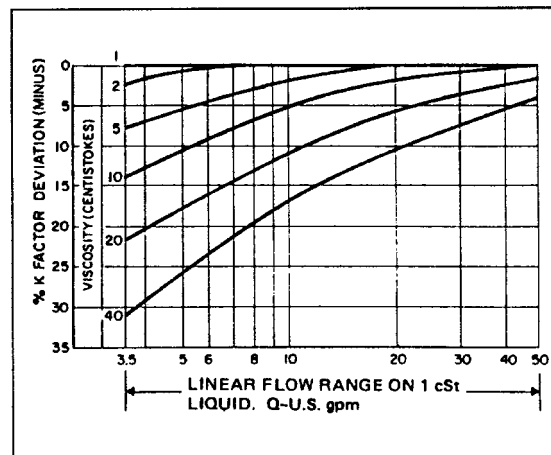

Figure 11. Viscosity Effect – Size Prefix Code 1 for 81A/81T

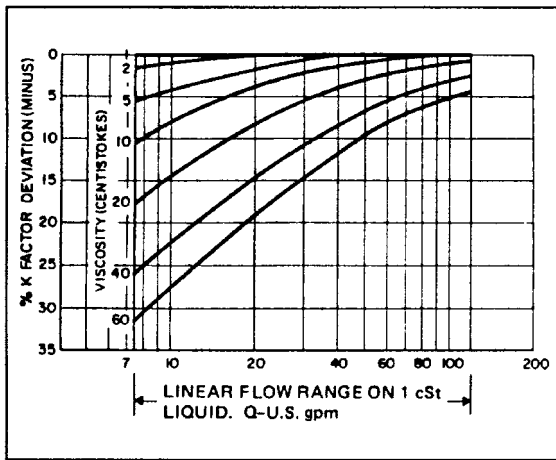

Figure 12. Viscosity Effect – Size Prefix Code 1- $\frac{1}{2}$  for 81A/81T

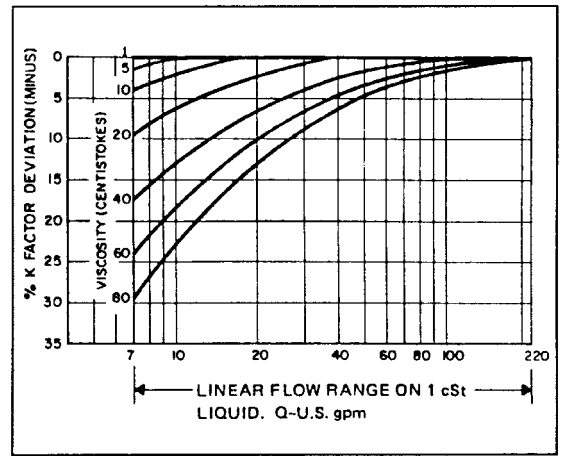

Figure 13. Viscosity Effect – Size Prefix Code 2 for 81A/81T

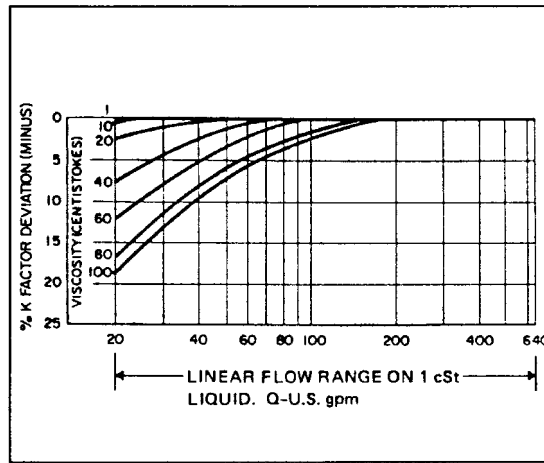

Figure 14. Viscosity Effect – Size Prefix Code for 81A Only

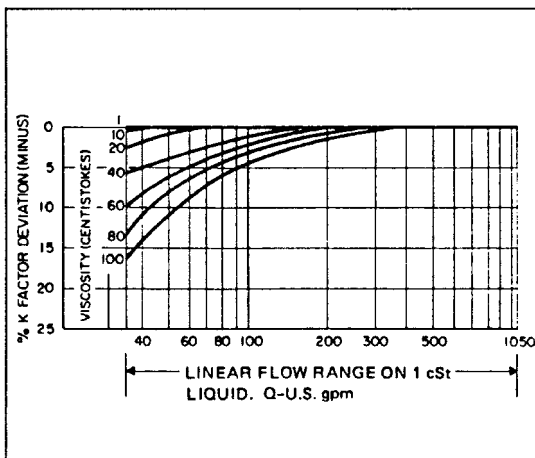

Figure 15. Viscosity Effect – Size Prefix Code 4 for 81A Only

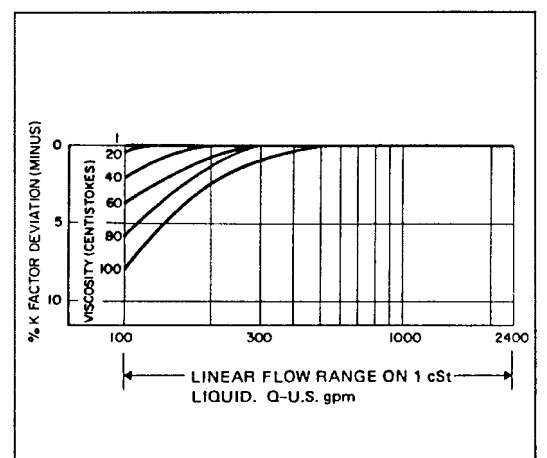
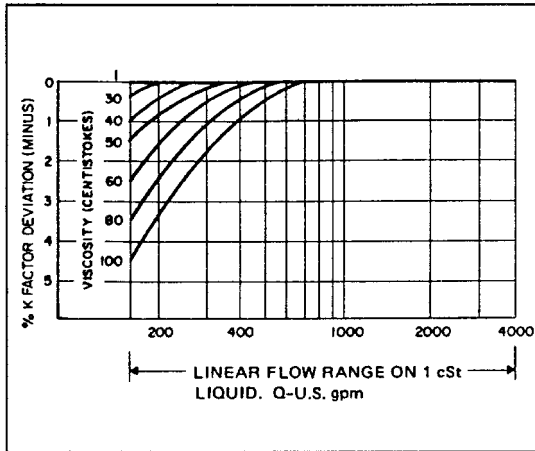
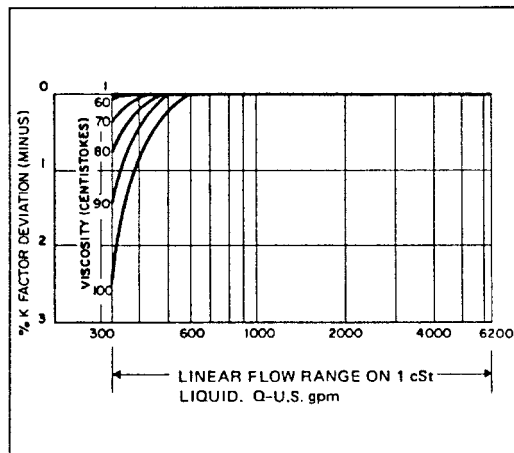

Figure 16. Viscosity Effect – Size Prefix Code 6 for 81A Only



**Figure 17. Viscosity Effect – Size Prefix Code 8 for 81A Only**



**Figure 18. Viscosity Effect – Size Prefix Code 10 for 81A Only**

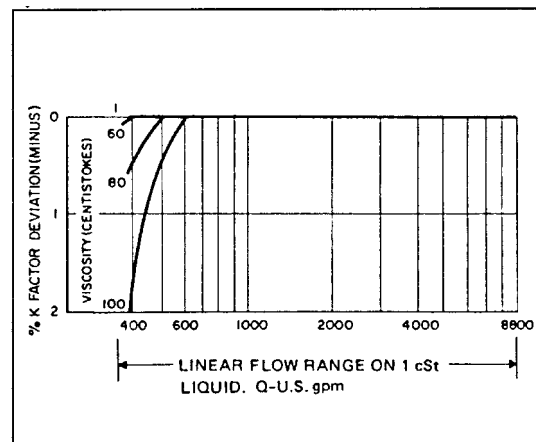

**Figure 19. Viscosity Effect – Size Prefix Code 12 for 81A Only**

**12. GAS PURGING**

Cox Instrument's 81T Turbine Flowmeters are applied in many military and aerospace applications. The flow rates of corrosive chemicals are often measured. After such use, it is common practice to flush the flowmeters with solvents and purge them dry with nitrogen gas. Also, nitrogen gas is used to see if a flowmeter still works after not being used for extended periods. Maximum recommended purge rates for Turbine Flowmeters are shown in Figure 20. Observing these limits helps to avoid overspeeding and accelerated bearing wear.

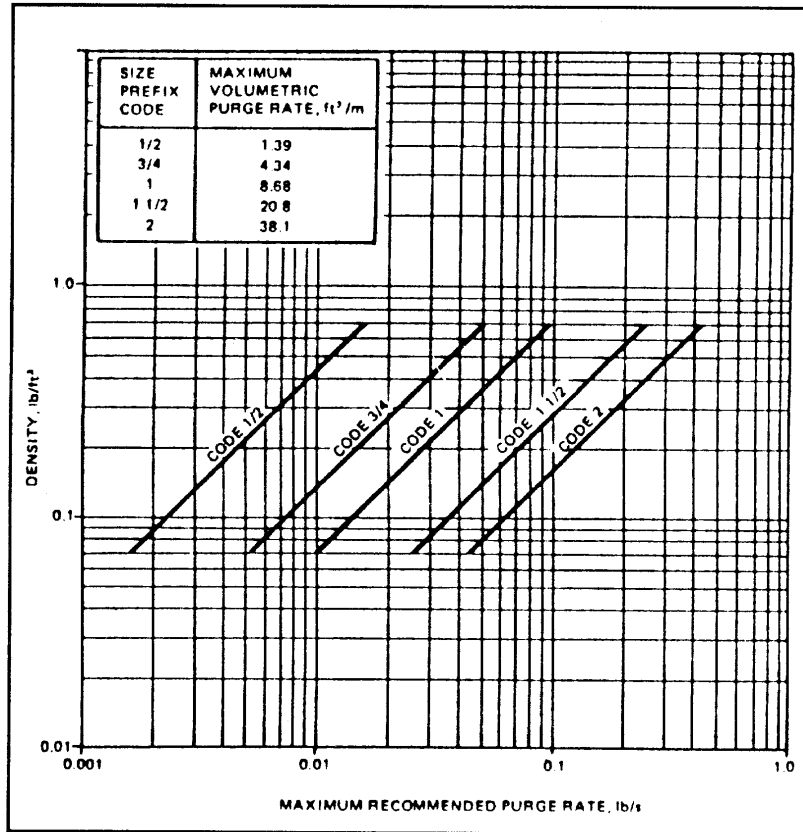

**Figure 20. Maximum Recommended Purge Rate Versus Density**

## II. INSTALLATION

Notes:

1. Gaskets must not protrude into the flow stream.
2. It is recommended that the flowmeter be installed with the pickup coil facing either horizontally or downward (to minimize condensation buildup).

**CAUTION - TO AVOID DAMAGING THE ROTOR, KEEP ALL FOREIGN MATERIAL OUT OF THE LINE DURING INSTALLATION**

### (i) Piping

Install flowmeter (Figure 22) so that it is free of magnetic field effects and vibration. In general, do not locate the flowmeter within 3 m (10 ft) of heavy electrical equipment.

The flowmeter should be mounted in a horizontal line and may be rotated in any direction on its axis.

Install the flowmeter so that arrow on the flowmeter body points in the direction of the flow.

A bypass should be provided if the flow cannot be interrupted for maintenance of strainer or flowmeter.

Inside diameter (I.D.) of the piping should match diameter of the flowmeter opening. Maximum recommended allowable mismatch is 8% of nominal diameter.

Note: Sizes 25 mm (1 in) and smaller are made to mate with Schedule 80 pipe. Sizes bigger than 25 mm (1 in), mate with Schedule 40 pipe.

Strainer recommendations, see Process Piping and Connections sections.

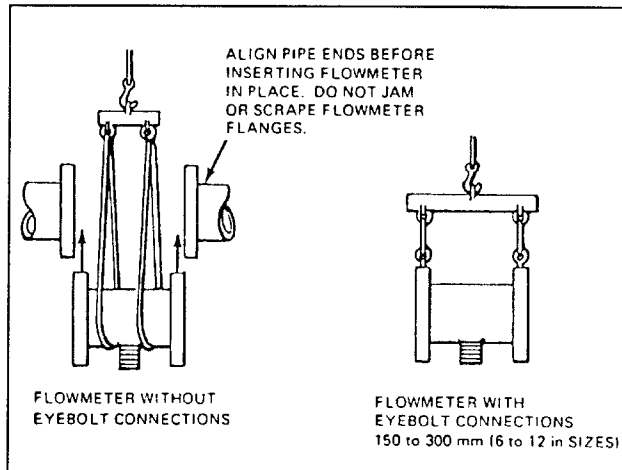

Figure 21. Flowmeter Handling and Alignment

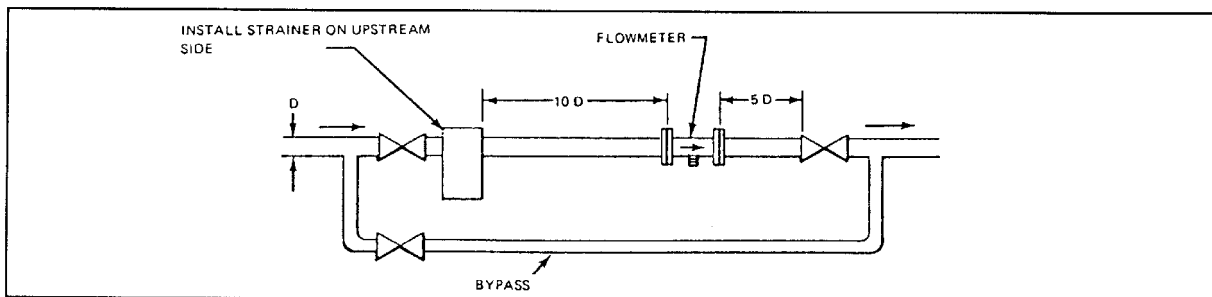

Figure 22. Flowmeter Installation with Shutoff Valves

### III. OPERATIONS

#### (i) Starting-Up Precautions

Notes:

Outlet Pressure (absolute): Should be greater than twice the maximum pressure drop, plus 1.3 times the vapor pressure (absolute) of measured liquid.

When flow is stopped, close downstream shutoff valve (Figure 22) to keep system full.

1. Before liquid is allowed to flow through flowmeter (see Figure 22), remove flowmeter and install a length of pipe in its place.
2. Thoroughly flush line to remove solids that could damage flowmeter rotor.
3. Replace the flowmeter.
4. Start process flowing through flowmeter gradually to prevent bearing damage by overspeeding rotor.
5. Bleed system of air before measurements are attempted. The system must be full of process liquid.

#### (ii) Conduit-Type Wiring

Notes:

Suitable for Class I, Groups C and D, Division 1 operation.

Adaptor fitting kit permits connection box or field-mounted preamplifier to be close coupled to flowmeter.

**CAUTION: DO NOT PERMIT WATER OR MOISTURE TO ENTER CONDUIT BOXES OR TO CONTACT CONDUCTORS.**

#### (iii) Wiring Using A Connection Box

Refer to Figure 23 for a connection box example. When exclusive conduit is used (no other leads in conduit), leads may be 0.50 mm<sup>2</sup> or 22 AWG screened (shielded) cable, or equivalent.

#### (iv) Wiring Using A Field-Mounted Preamplifier

Refer to Figure 24 for an example of a field-mounted preamplifier.

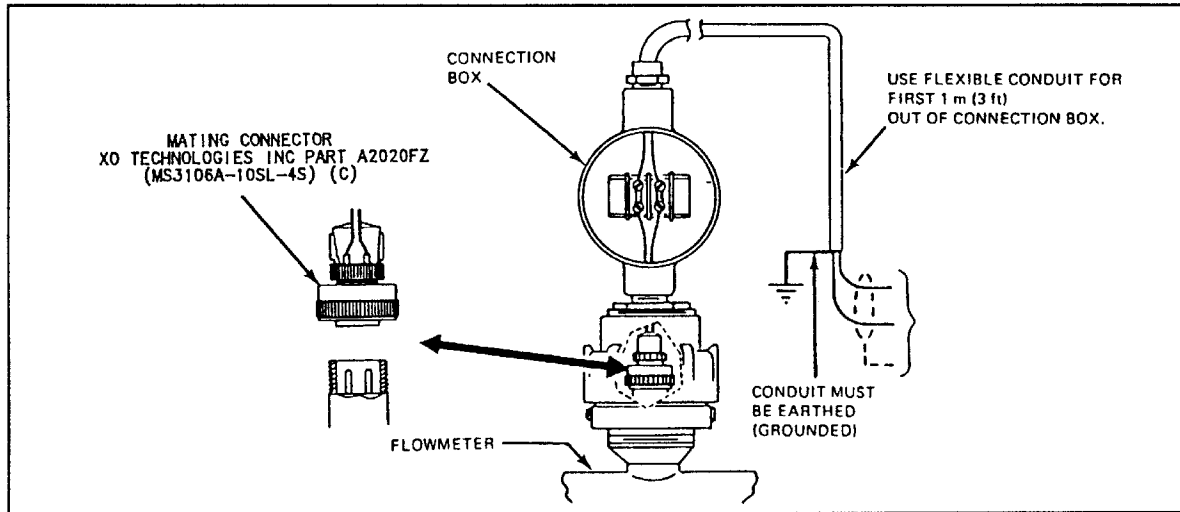

**Figure 23. Wiring Using a Connector Box**

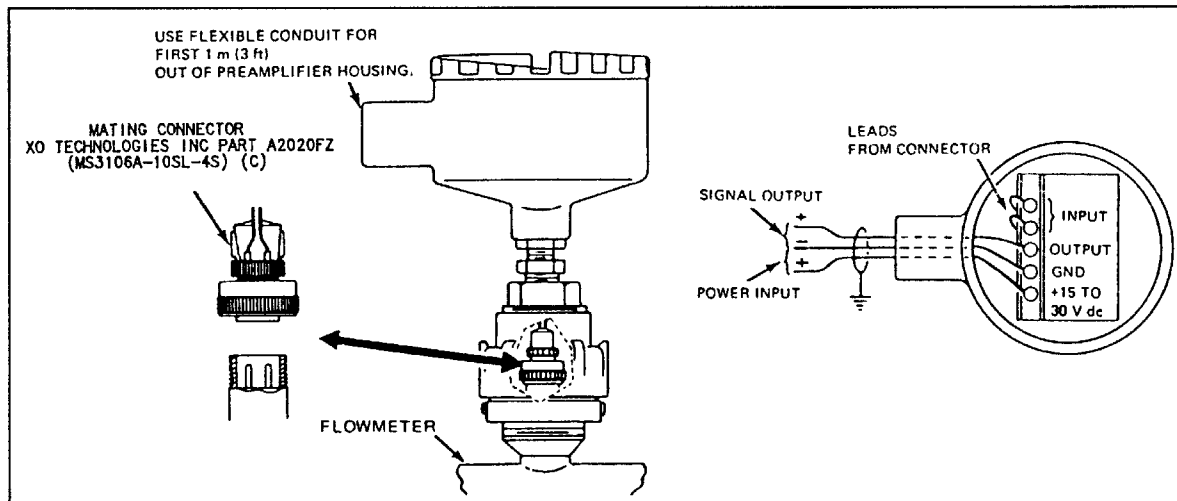

**Figure 24. Wiring Using a Field-Mounted Preamp**

## 1. SYMPTONS, PROBABLE CAUSES, AND SOLUTIONS

SYMPTOMS AND PROBABLE CAUSES	SOLUTIONS
1. No flow indication	
A. Strainer (if included) obstructing flow.	Clean or replace strainer screen.
B. Defective or improperly positioned valve.	Correct valve position or replace valve.
C. Pickup coil not properly seated in coil well.	Reseat coil. Refer to COIL REMOVAL.
D. Coil winding open or shorted.	Check coil. Refer to COIL TEST.
E. Broken or earthed (grounded) transmission cable.	Repair or replace cable.
F. Defective readout device.	Repair or replace readout device.
G. Foreign material jammed between rotor and housing.	Disassemble and clean.
2. Flow indication with no flow in the line.	
A. Defective chassis earthing connection at readout device.	Repair chassis earth connection.
B. Strong ac interference.	Reroute cable, install cable in conduit, install field mounted preamplifier, or relocate flowmeter.
C. Strong vibration causing rotor to turn.	Support piping or relocate flowmeter.
D. Flow actually occurring.	Repair or replace defective valve.
3. Erratic measurement or lack of repeatability.	
A. Foreign material obstructing flow.	Disassemble and clean.
B. Flowmeter installed with insufficient straight pipe upstream or downstream.	Correct piping and provide sufficient straight run. Refer to process and piping connections.
C. Not a full flowmeter or heavy air entrainment in process liquid.	Arrange or repair piping to avoid entrainment and bleed system on start-up.
D. Strong ac interference.	Reroute cable, install cable in conduit, install field-mounted preamplifier.
E. Attempting to operate flow rate below specified minimum.	Increase flow rate to at least specified minimum.
F. Inlet pressure too low.	Increase inlet pressure.
4. Indicated flow greater than actual flow.	
A. Heavy air entrainment in line.	Arrange or repair piping to avoid entrainment and bleed system on start-up.
B. Inlet pressure too low.	Increase inlet pressure.
C. Using incorrect calibration (K) factor.	Use correct calibration factor listed on Data Calibration Report that came with flowmeter.
D. Strong ac interference.	Reroute cable, install cable in conduit, install field-mounted preamplifier (readout device wiring must be altered to bypass built-in preamplifier), or relocate flowmeter.
5. Indicated flow less than actual flow.	
A. Process liquid viscosity significantly higher than originally specified.	Correct liquid viscosity or use corrected calibration (K) factor. Refer to CALIBRATION CURVES. See Figures 7 thru 19.
B. Pickup coil not properly seated in coil well.	Reseat coil. Refer to COIL REMOVAL.
C. Defective readout device.	Repair or replace readout device.
D. Using incorrect calibration (K) factor.	Use correct calibration factor listed on calibration report that came with flowmeter.

## IV. MAINTENANCE

Normal maintenance of the 81AF and 81AT Turbine Flowmeters consists of periodic inspection of interior parts for signs of wear or corrosion, cleaning or replacing parts when required; and, if necessary, checking meter calibration.

The frequency of this periodic maintenance will depend primarily on the service to which the meter is subjected. It is suggested that the first inspection be made after six months' use. Future intervals between inspections will depend largely on results found after the initial inspection.

### 1. MAINTENANCE TOOLS

All maintenance should be performed in a clean area with good lighting. Because some of the parts are very small, a magnifying glass and a suitable work light will be very helpful. The tools listed are all available commercially.

#### (i) For 1/2 and 5/8 Inch Flowmeters

- Tapered, pointed tweezers
- Retaining ring pliers, Waldes Truarc No. 21 or equivalent
- Needle probe with point >2"

#### (ii) For 3/4 through 2 Inch Flowmeters

- Screwdriver
- Socket wrench set
- Torque wrench 1.5 to 22 lb-in range

### 2. REFERENCE INSTRUCTIONS

81AF and 81AT Turbine Flowmeters, Installation and Operation.

PA111, 112, 115 Field-Mounted Preamplifier

PA422 Analog Amplifier (4 to 20 mA dc Output)

### 3. CALIBRATION

The 81AF and 81AT Turbine Flowmeters have excellent calibration stability. If abrasive liquids are being measured or if long-term precise calibration is required, periodic calibration checks should be made. If the bearings are changed, the calibration must be checked. Calibration consists of passing precise volumes of liquid through the flowmeter using a gravimetric or volumetric proving system together with a gated pulse counter.

In this manner, the actual values of K (pulses per U.S. gallon) can be determined over the linear range of the flowmeter (refer to the calibration data report that came with the flowmeter). From these values the mean K value (arithmetic mean between maximum and minimum values) can be calculated.

Individual plant practice will determine the actual proving procedure.

If calibration of the flowmeter cannot be accurately obtained, adjustment of the vane trim tabs or shaft support may be required.

Note:

Calibration should not be attempted except by experienced personnel. For optimum results, return the meter to S&K for recalibration.

**4. COIL REMOVAL AND INSTALLATION**

**(i) Coil Removal**

1. Disconnect conduit box or field-mounted preamplifier assembly (if present) from meter body.
2. Remove connector plug from pickup coil.
3. Loosen coil locknut with a 7/8 in. deep-well socket wrench [50 mm (2 in.) min. depth].
4. Unscrew coil by hand.

**(ii) Coil Installation**

1. Screw in coil finger tight until it bottoms.
2. Tighten locknut to a torque of 20 to 40 N m (15 to 30 lb ft)
3. Reconnect plug to coil.
4. Reconnect conduit box or field-mounted preamplifier (if present) to meter body.

**5. COIL TEST**

1. Remove cover from conduit connection box or field-mounted preamplifier, and remove coil leads from termination strip.
2. Measure resistance between coil leads with an ohmmeter. If resistance is not 3100 ohms  $\pm$  10% at 21 deg. C (70 F), replace coil.
3. Measure resistance between one lead and box. If resistance is not infinite, replace coil.

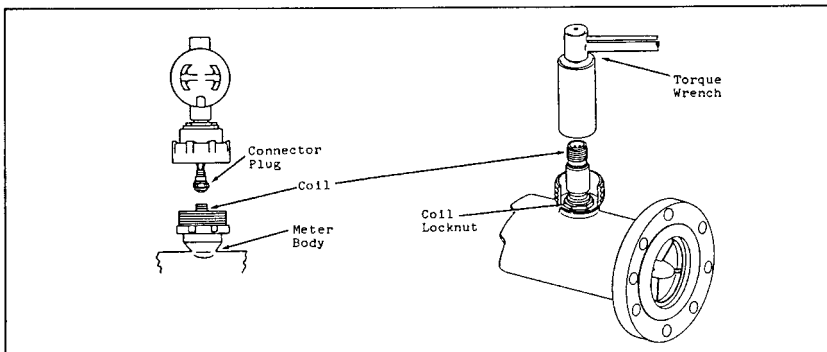

**Figure 25. Coil Removal and Installation**

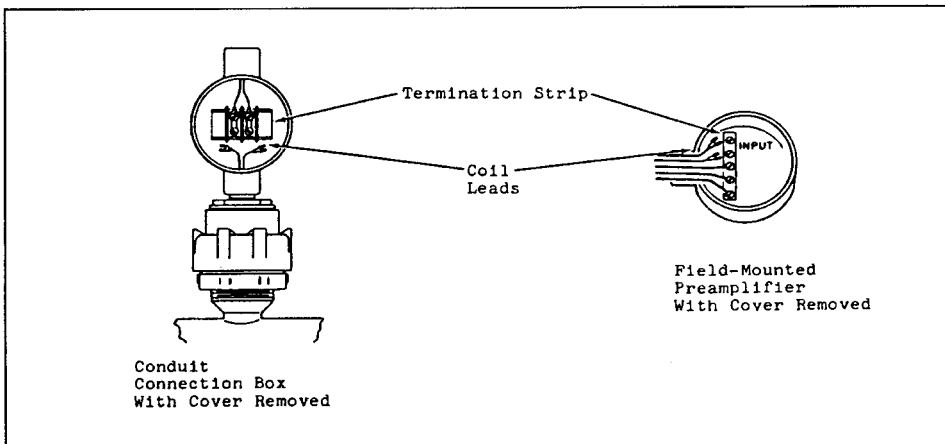

**Figure 26. Coil Test**

## 6. DISASSEMBLY AND ASSEMBLY PROCEDURES FOR 1/2" SIZES

### (i) Disassembly

Note:

All illustrations shown are for the 81AT Series; however, they apply to the 81AF Series as well.

1. Remove flowmeter from pipeline.  
**WARNING Wear safety glasses and use special care when performing Step 2. Retaining ring may snap out of groove in an undetermined direction with high velocity.**
2. Remove retaining ring with sharp object such as a needle probe from upstream side.
3. Carefully shake out sleeve, vane, bearings, rotor, and shaft into palm of hand. If parts cannot be removed freely, use a pair of needle nose pliers on vane pulling straight out.
4. Mark upstream end of rotor for correct positioning during reassembly.  
Note: The downstream vane is not normally removed. If it is to be removed, mark the upstream vane also.
5. Remove bearings from rotor and wash all parts with solvent that is process compatible.
6. Wash downstream vane also.
7. If water is used as solvent, flush parts with isopropyl alcohol.
8. Inspect all parts for damage or wear. If required, replace parts.

### (ii) Assembly

1. If the downstream vane has been removed, insert the vane and sleeve, making sure that the vane tab is in the upset in the shoulder of the body housing. Lock in with retaining ring.
2. Insert shaft into upstream vane.
3. Insert bearings into rotor, with open ends of bearings facing downstream (away from upstream mark).
4. Slide the rotor assembly onto the shaft. Check that the bearings are seated in the recess of the rotor and that the marked end of rotor is in the upstream position.
5. Insert assembly into body housing. Align vanes (upstream and downstream) making sure vane tab is in upset in shoulder of body housing.
6. Install sleeve and retaining ring.
7. Check rotor for free turning by gently blowing into one end of meter.  
Note: If rotor does not turn freely, repeat assembly process.
8. Reinstall flowmeter in pipeline. Refer to MI019-117.  
Note: If bearings are replaced, it may be necessary to recalibrate the flowmeter. Refer to Calibration Section.

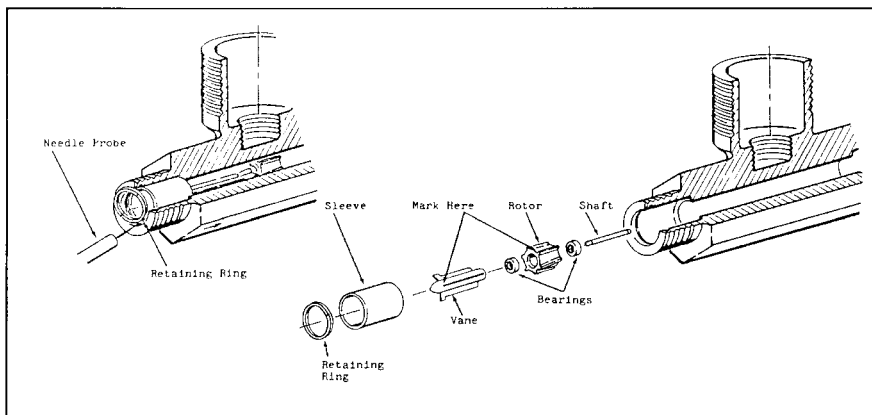

**Figure 27. Disassembly Procedures for 1/2" Sizes**

**7. DISASSEMBLY AND ASSEMBLY PROCEDURES FOR SIZES 3/4" AND LARGER**

**(i) Disassembly**

Note: All the illustrations shown below and on the following pages are for the 81AF Series Flowmeter; however, they apply to the 81AT Series Flowmeters as well.

1. Remove flowmeter from pipeline.
2. With proper size screwdriver or nutdriver and socket wrench, remove locknut from shaft.
3. Slide shaft, bearings, rotor, and sleeve out of body housing.  
Note: Arrow on rotor points downstream.
4. Remove bearing and sleeve from rotor and wash all parts with a solvent that is process compatible.
5. Flush shaft hole in vane and wash the vane itself.
6. If water is used as solvent, flush part with isopropyl alcohol.
7. Inspect all parts for damage or wear. If required, replace parts.

**(ii) Assembly**

1. Slide bearing on shaft with flange side of bearing against shaft head.
2. Slide sleeve and rotor onto shaft, making sure bearing fits into rotor.
3. Slide second bearing onto shaft. Bearing must be flange side out to fit into rotor.  
Note: The arrow on the rotor must be pointed downstream (toward the head of shaft).

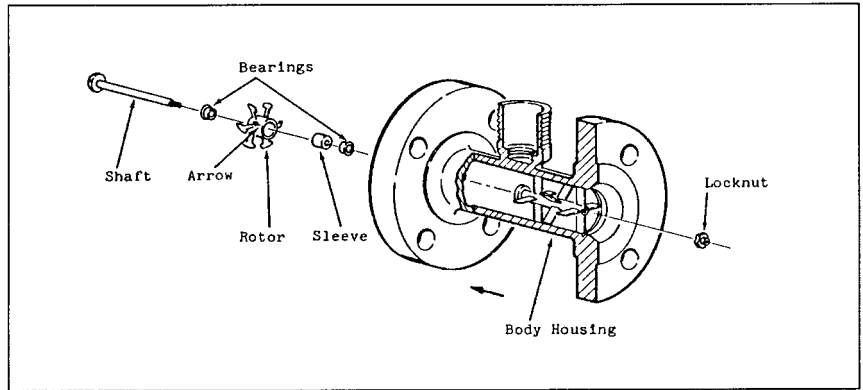

**Figure 28. Disassembly and Assembly Procedures for Sizes 3/4" and Larger**

4. From the downstream side, insert rotor assembly in body housing with shaft going through vane. Check that bearings are properly seated in rotor.
5. Holding the shaft in place with a screwdriver or nutdriver, tighten the locknut with a torque wrench to the torque specified below.
6. Insert cotter pin on size 4" and larger flowmeter.
7. Check rotor for free turning.  
Note: If rotor does not turn freely, repeat assembly process.
8. Reinstall flowmeter in pipeline. See Figure 22.  
Note: Bearings can be replaced in size 1", Flowmeter and larger without causing a shift in calibration factor. However, for optimum accuracy, it may be necessary to recalibrate the flowmeter. Refer to Calibration section.

Flowmeter Size	Torque Range	
3/4	176 to 247 mN-m	(25 to 35 oz-in)
1	3 to 5 N-m	(3 to 4 lb-in)
1 1/2	11 to 16 N-m	(10 to 15 lb-in)
2	18 to 24 N-m	(16 to 22 lb-in)
3 through 12	Refer to note below	
Note: With sizes 3 through 12, locknut should be tightened so that all mating surfaces are in contact. Shaft must NOT be free to turn.		

**V. PARTS LIST**

Figure E2301A

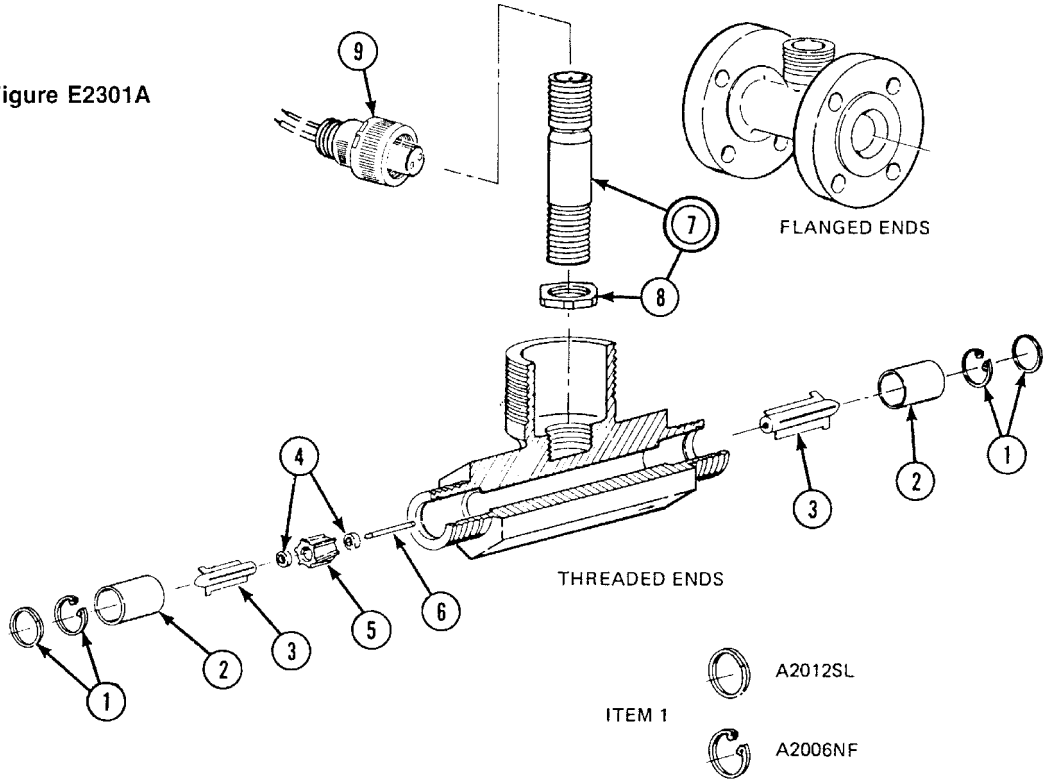

**Flanged And Threaded Ends 15mm (1/2 in) Size**

Size Prefix*	Retaining Ring Item 1	Spacer Item 2	Support Item 3	Bearing Item 4	Rotor Item 5	Shaft Item 6	Pick-up Coil Item 7	Retaining Nut Item 8	Electrical Connector Item 9
½	A2012SL	A2046PL	A2017TK	A2011AP	A2039QG	A2012RW	A2010SE	A2003MK	A2020FZ
½-1	A2006NF	A2046 PM	A2017TM	A2011AN	A2039QB	A2017TN	A2010SE	A2003MK	A2020FZ
1/2-2	A2006NF	A2046PM	A2017TM	A2011AN	A2039SF	A2017TN	A2010SE	A2003MK	A2020FZ

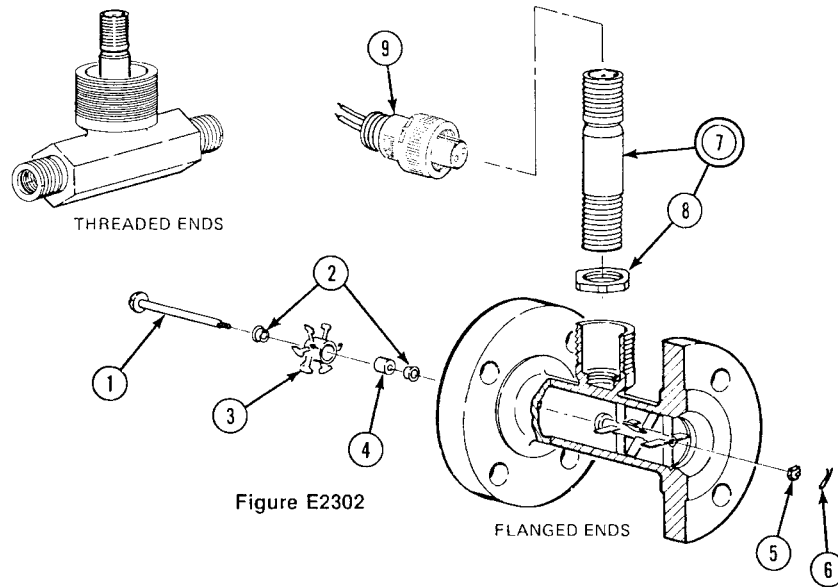

**Flanged And Threaded Ends  
Sizes 20 Through 300 mm (3/4 Through 12 in)**

Size Prefix*	Shaft Item 1	Bearing – Item 2		Rotor Item 3	Bearing Spacer Item 4	Lock-Nut Item 5	Cotter Pin Item 6	Pick-up Coil Item 7	Retaining Nut Item 8	Electrical Connection Item 9
		Phenolic Retainer	With ss Retainer							
¾	A2014CX	-	A2010ZB	A2048QP	A2014CY	A2004RS	-	A2010SE	A2003MK	A2020FZ
1	A2014BZ	A2011BB	A2011AC	A2014AF	A2014KY	A2004RZ	-	A2010SE	A2003MK	A2020FZ
1 ½	A2014CA	A2011BC	A2011AF	A2014KX	A2014CM	A2004RC	-	A2010SE	A2003MK	A2020FZ
2	A2048BS	A2011BE	A2011AM	A2014CF	A2014CB	A2004RF	-	A2010SK	A2003MK	A2020FZ
3	A2014EA	A2011AZ	A2011AA	A2019KW	A2014EB	A2004RL	-	A2010SK	A2003MK	A2020FZ
4	A2014EN	A2011AY	A2010ZZ	A2019KY	A2014ES	A2004PY	A2010NB	A2010SK	A2003MK	A2020FZ
6	A2014EW	A2011BA	A2011AB	A2019KX	A2014ET	A2004PZ	A2010NC	A2010SK	A2003MK	A2020FZ
8	A2014EZ	A2011BF	A2011AL	A2019KZ	A2014FN	A2004RA	A2010NC	A2010SK	A2003MK	A2020FZ
10	A2014AS	A2011BL	A2011AR	A2019LA	A2017NP	A2004RB	A2010NE	A2010SK	A2003MK	A2020FZ
11	A2014KR	A2011BK		A2019LB	A2014AP	A2004RB	A2010NE	A2010SK	A2003MK	A2020FZ

Note: If housing is damaged, order complete Turbine Flowmeter.

**Flanged and Threaded Ends  
Sizes 100 through 200 mm (4 through 8 in)  
With Shrouded Rotor**

Size Prefix* -A	Shaft Item 1	Bearing – Item 2		Shrouded Rotor Item 3	Bearing Spacer Item 4	Lock-Nut Item 5	Cotter Pin Item 6	Pick-up Coil Item 7	Retaining Nut Item 8	Electrical Connection Item 9
		Phenolic Retainer	with ss Retainer							
4-A	A2014EN	A2011AY	A2010ZZ	A2017NR	A2014ES	A2004PY	A2010NB	A2010SK	A2003MK	A2020FZ
6-A	A2014EW	A2011BA	A2010AB	A2014FF	A2014ET	A2004PZ	A2010NC	A2010SK	A2003MK	A2020FZ
8-A	A2014EZ	A2011BF	A2010AL	A2014LA	A2014FN	A2004RA	A2010NC	A2010SK	A2003MK	A2020FZ

Notes:

1. If housing is damaged, order complete Turbine

**VI. DIMENSIONS**

Flange Meter Dimensions													
Size Code	A	B	C	ANSI Flange Rating Class	Flange Diameter		Bolt Hole Diameter		Bolt Circle Diameter		Bolt Hole Quantity	81 & 81A Series Approx. Weights	
	<u>in</u>	<u>in</u>	<u>in</u>		in	mm	in	mm	in	mm		Lbs.	Kg.
	mm	mm	mm		mm	mm	mm	mm	mm	mm		mm	mm
1/2	<u>2.73</u>			150	3.50	89	0.62	16			4	5	2.3
	69.3			300	3.75	95	0.62	16	2.62	67	4	7	3.2
				600	3.75	95	0.62	16	2.62	67	4	8	3.6
3/4	<u>2.87</u>	<u>2.50</u>	<u>5.00</u>	150	3.88	99	0.62	16	2.75	70	4	6	2.7
	72.9	63.5	127.0	300	4.62	117	0.75	19	3.25	83	4	8	3.6
				600	4.62	117	0.75	19	3.25	83	4	10	4.5
1	<u>2.99</u>			150	4.25	108	0.62	16	3.12	79	4	7	3.2
	75.9			300	4.88	124	0.75	19	3.50	89	4	9	4.1
				600	4.88	124	0.75	19	3.50	89	4	11	5.0
1-1/2	<u>3.21</u>	<u>3.00</u>	<u>6.00</u>	150	5.00	127	0.62	16	3.88	99	4	10	4.5
	81.5	76.2	152.4	300	6.12	155	0.88	22	4.50	114	4	14	6.4
				600	6.12	155	0.88	22	4.50	114	4	16	7.3
2	<u>3.45</u>	<u>3.58</u>	<u>6.50</u>	150	6.00	152	0.75	19	4.75	121	4	15	6.8
	87.6	90.9	165.1	300	6.50	165	0.75	19	5.00	127	8	20	9.1
				600	6.50	165	0.75	19	5.00	127	8	24	10.9
3	<u>4.15</u>	<u>6.59</u>	<u>10.00</u>	150	7.50	191	0.75	19	6.00	152	4	30	13.6
	105.4	167.4	254.0	300	8.25	210	0.88	22	6.62	168	8	40	18.1
				600	8.25	210	0.88	22	6.62	168	8	46	20.9
4	<u>4.57</u>	<u>8.43</u>	<u>12.00</u>	150	9.00	229	0.75	19	7.50	191	8	42	19.1
	116.1	214.1	304.8	300	10.00	254	0.88	22	7.88	200	8	65	29.5
				600	10.75	273	1.00	25	8.50	216	8	95	43.1
6	<u>5.54</u>	<u>10.36</u>	<u>14.00</u>	150	11.00	279	0.88	22	9.50	241	8	80	36.3
	140.7	263.1	355.6	300	12.50	318	0.88	22	10.62	270	12	120	54.4
				600	14.00	356	1.12	28	11.50	292	12	200	90.7
8	<u>6.45</u>	<u>13.32</u>	<u>18.00</u>	150	13.50	343	0.88	22	11.75	298	8	143	64.9
	163.8	338.3	457.2	300	15.00	381	1.00	25	13.00	330	12	200	90.7
				600	16.50	419	1.25	32	13.75	349	12	315	142.9
10	<u>7.43</u>	<u>20.01</u>	<u>25.00</u>	150	16.00	406	1.00	25	14.25	362	12	250	113.4
	188.7	508.3	635.0	300	17.50	445	1.12	28	15.25	387	16	325	147.4
				600	20.00	508	1.38	35	17.00	432	16	510	231.3
12	<u>8.35</u>	<u>24.14</u>	<u>30.00</u>	150	19.00	483	1.00	25	17.00	432	12	400	181.4
	212.1	613.2	762.0	300	20.50	521	1.25	32	17.75	451	16	500	226.8
				600	22.00	559	1.38	35	19.25	489	20	695	315.2

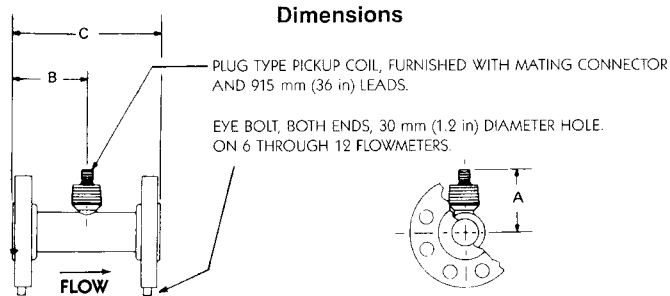

81 Series Turbine Flowmeter Manual  
Part #  
Rev. 4/04/2007  
01/01 Printed in USA  
090804

