

## Industrial Flowmeter

# Oval Gear

## Industrial Oval Gear Flowmeter

*Explosion-proof Terminal Enclosure*

### Description

The COX Flow Measurement **Industrial Oval Gear Meter** is a low-flow, positive displacement flowmeter designed for clean fluids. The **Industrial Oval Gear Meter** is unaffected by shifts in output due to viscosity variance, making it an ideal choice for use with lubricating oil, paint, epoxies, greases, polyurethane, additives, syrups, glue, hydraulic oil and any fluid compatible with the materials of construction.

The **Industrial Oval Gear Meter** is best suited for fluids with a viscosity range between 5 to 1000 centipoise and does not require flow straighteners upstream or downstream. The oval meter design minimizes slippage between the gears and the measuring chamber wall. As a result, the meter is less affected than other designs by the liquid's viscosity and lubricity.

Exceptional repeatability of  $\pm 0.03\%$  and linearity within  $\pm 0.5\%$  over a wide operating range make this oval gear meter an excellent choice for precision blending or metering. The design offers durable construction with 1/2" NPT process ports or flange adapters. The meter is equipped with an explosion-proof terminal enclosure and ATEX/Intrinsically Safe approvals, meeting the needs of hazardous area locations.



FM78587  
AS9100 Rev. B and  
ISO 9001:2008



**Oval Gear Flowmeter**  
ILR741 Terminal Enclosure

### Applications

- Blending
- Inventory management
- Dispensing
- Batching
- Flow monitoring

### Benefits

- NVLAP-accredited calibrations
- Highly repeatable:  $\pm 0.03\%$
- Dependable accuracy:  $\pm 0.5\%$  or better
- Exceptionally repeatable over a wide range of viscosities
- Hermetically-sealed reed switch output
- No flow straighteners required
- Able to run various fluids without loss of calibration
- Choice of registers and signal outputs
- ATEX approval for Intrinsically Safe applications

### Features

- Rugged, simplistic design
- 316L stainless steel spindle, gear & housing
- Minimum number of wear parts
- Proven Graphalloy bearing
- Factory calibrated (custom calibrations optional)
- Compact design with integral registers
- Simplistic pulsed output
- Vertical or horizontal installation

### MATERIALS OF CONSTRUCTION

MATERIALS OF CONSTRUCTION	
Housing	316L Stainless Steel or 6061 Aluminum
Cover	316L Stainless Steel or 6061 Aluminum
Spindle	316L Stainless Steel
Gears	316L Stainless Steel or LCP (plastic)
Bushing	Graphalloy (for stainless gears), no bushing for LCP
O-ring	<i>Standard:</i> Stainless – Aflas Aluminum – Viton <i>Optional:</i> Buna, EPDM, Aflas, Viton
Cover Screws	Stainless Steel
Magnet	Alnico 500

# Oval Gear

## Operating Principle



Fluid enters the inlet port and then passes through the metering chamber. Inside the chamber, fluid forces the internal gears to rotate before exiting through the outlet port. Each rotation of the gears displaces a specific volume of fluid. As the gears rotate, a magnet on each end of the gear passes a reed switch in the top-mounted register's circuit board. The reed switches send pulses to the microprocessor in the register to change the LED display segments. The oval gear meter can be used in conjunction with a variety of industrial registers.

Precision, robust oval gears can be removed for cleaning by removing four bolts from the bottom plate. Screw driver slots allow for leveraging the plate evenly from the housing. Proper gear alignment is obtained when one oval gear is perpendicular to the other and they both rotate freely.



## Model Number

**I O G S** - **0 8** - **N P T** - **A** -

### Housing

S = 316 SST  
Rotor 316L  
O-ring Aflas std.

A = Aluminum  
Rotor PPS/LCP  
O-ring Viton std.

### Size

08 = 1/2"  
12 = 3/4"  
16 = 1"

### End Fittings

NPT = U.S. pipe threads ANSI/ASME B1.20.1  
150 = 150# Flange  
300 = 300# Flange (only offered in SST)

### Special Options

XXX = 3 digit option code

### O-rings

A = Aflas  
B = BUNA  
E = EPDM  
V = Viton

NOTE: Rotor made of PPS/LCP is known for high dimensional stability, excellent high-temperature performance and chemical resistance. It is unaffected by alcohols, ketones, chlorinated aliphatic compounds, esters, aliphatic hydrocarbons, organic acids, toluene, liquid ammonia, etc. However, it is not recommended for dilute hydrochloric and nitric acids and concentrated sulfuric acid. PPS is also attacked by strong oxidizing agents such as bromine water, chromic acid and sodium hypochlorite, which cause deterioration at elevated temperatures. The rotor is insensitive to moisture.

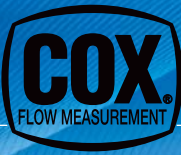

## Performance Specifications

Standard calibrations are performed in water, optional viscosity calibrations are available. Optional calibrations include 5 data points, evenly spaced over the standard range of the flowmeter to determine the average K-Factor. Consult with our application engineers for specifying optional calibrations.

FLOW RANGE > 5.0 cP					
Size/Material	Range GPM	Range LPM	Fluid Viscosity	Accuracy (% of reading)	Repeatability (% of reading)
1/2"	0.25 – 8	1.0 – 30	> 5.0 cP	±0.5	±0.03
3/4"	0.50 – 16	2.0 – 60	> 5.0 cP	±0.5	±0.03
1"	0.60 – 18	2.3 – 68	> 5.0 cP	±0.5	±0.03

FLOW RANGE < 5.0 cP					
Size/Material	Range GPM	Range LPM	Fluid Viscosity	Accuracy (% of reading)	Repeatability (% of reading)
1/2"	0.50 – 6.6	2.0 – 25	< 5.0 cP	±2.0	±0.03
3/4"	1.20 – 14	4.5 – 53	< 5.0 cP	±2.0	±0.03
1"	1.40 – 16	5.3 – 60	< 5.0 cP	±2.0	±0.03

OPERATING FLUID TEMPERATURES		
Rotor Material	Min. Operating Temp. (°F/°C)	Max. Operating Temp. (°F/°C)
Stainless Steel	-22/-30	240/120
Plastic (PPS/LCP)	-22/-30	176/80

Maximum Storage Temperature: 172°F (79°C)

Minimum Storage Temperature: -22°F (-30°C)

PRESSURE RATING	
NPT Ports	Flanged Connections
800 psi	150# – 285 psi
	300# – 740 psi

For higher pressure applications, please check with the factory.

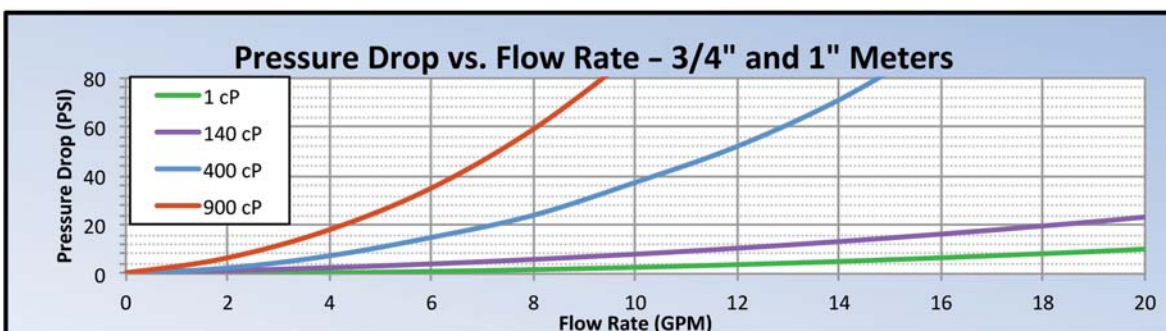
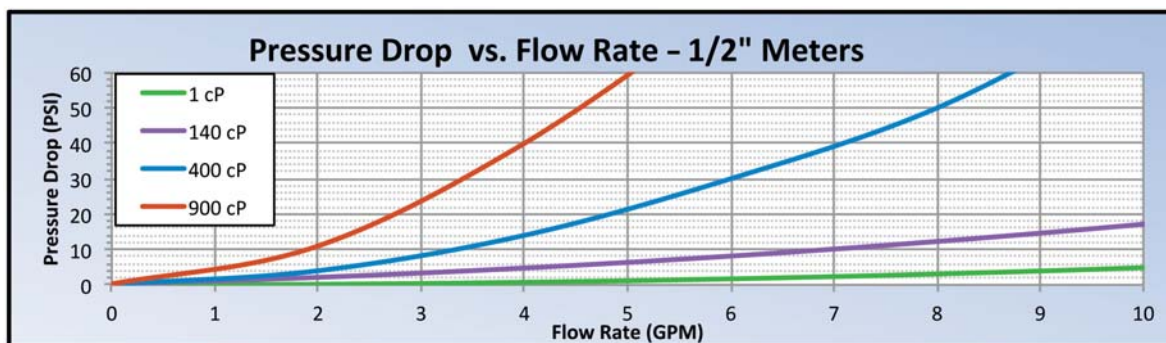

# Oval Gear

## Oval Gear with Integral Registers

The ER420 Series is offered in aluminum or high-impact modeled housings and contains a microprocessor. This unit has a large transfective LCD capable of displaying both total and rate. The ER420 Series includes several important features, such as K-factors, measurement units, linearization, signal selection, etc. All settings are stored in EEPROM memory and will not be lost in the event of a power failure or a drained battery. The ER420 Series is available with 115-220 VAC, 24 AC or loop powered.

The ILR700 Series Registers have a 5-year battery life and a large 6-digit display. The display allows selectable rate and total indication with scalable units of measure. Quadrature pulse, scalable pulse and analog 4-20 mA output are available.

See the Oval Gear Meter Registers Technical Briefs (ITB-192) and the ER420 Flow Rate/Totalizer Technical Brief (ITB-174) for more information on the available register options.



**ER420 Series  
Register/Linearizer**



**Powered Register/  
Transmitter**

**ILR700 Series**



**Battery Register**

**Transmitter**

## Dimensions with Registers

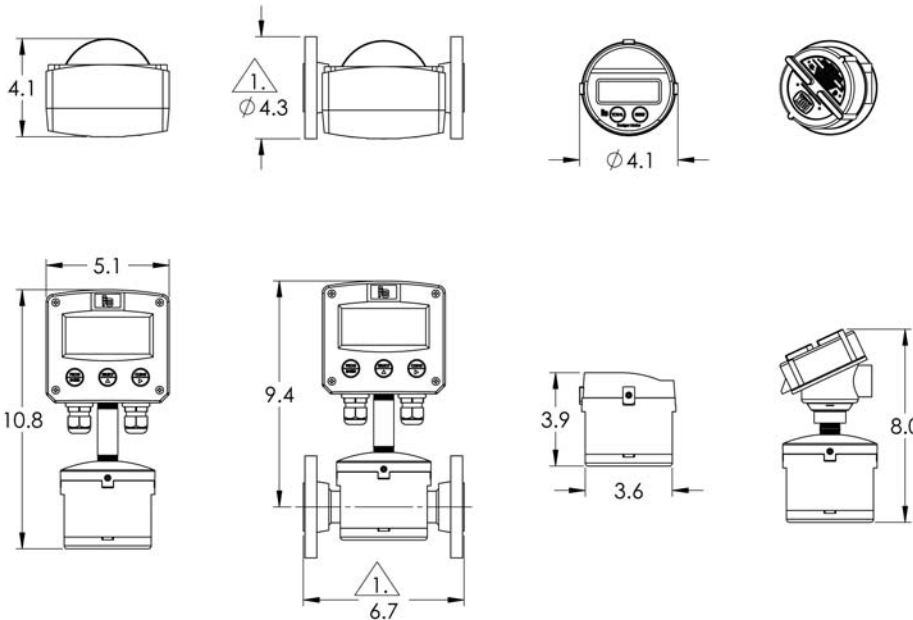

**NOTE:**

△ Dimension is based upon 1" class 150 B16.5 flange. O.D. of flange will vary with meter size and flange class.  
All dimensions are in inches.

Please contact our application engineers to assist you with special configurations and to find out more about our batch controllers. Visit our website at [www.coxflow.com](http://www.coxflow.com).

*Representative*



**Call COX Flow Measurement for application assistance and proper system configuration.**

15555 North 79th Place, Scottsdale, AZ 85260  
P: (480) 948-3789 F: (480) 948-3610 [sales@coxflow.com](mailto:sales@coxflow.com)  
© 2011 COX Flow Measurement CXDB0003-11 Rev A